



SPECIALTY TOP CO.

INSTALLATION INSTRUCTIONS SAMURAI AERO TOP PART #881-020

Thank you for purchasing Specialty's Convertible Top for your vehicle. It has been designed for great fit and long wear. Please read and follow, precisely, all installation instructions provided when installing top. Failure to do so may result in a poor fitting top and could place occupants in a potentially hazardous situation.

TOOLS REQUIRED

1/8" DRILL BIT #2 PHILLIPS SCREWDRIVER
ELECTRIC DRILL

INSTALLATION TIPS

Before you begin installing this top, here are a few tips to make installation easier.

This top should be installed where the temperature is above 72 degrees Fahrenheit. Below this temperature, the top may contract making it difficult to install.

It is normal for a top to contract and wrinkle when stored in the shipping carton. The top will relax and wrinkles will disappear within a few days of installation as fabric adjusts to shape of mounting hardware.

Step 1. Place "L" bracket (Item 1) over hole on slanted roll bar support brace. Secure to vehicle with 8MM x 40MM hex bolt (Item 2) through lower hole in "L" bracket and into threaded hole in roll bar brace. Repeat for the other side. See figure 1.

Step 2. Place 1/4-20 x 1 1/2 hex bolt (Item 3) through off set holes in release bracket (Item 4) and through upper hole in "L" bracket. Secure with 1/4-20 lock nut (Item 5). Do not over tighten as these items need to pivot. Place 1/4-20 x 1 1/2" hex bolt (Item 3) through one side of release bracket (Item 4) support bow (Item 6) and the other side of release bracket. Secure with 1/4-20 lock nut (Item 5). Again these items need to pivot so do not over tighten. Repeat for the other side. See figure 1.

Step 3. Slip front edge of top into channel on top of windshield frame. See figure 2. Flip top over vehicle and rear support bow. Slide sewn in plastic on side panels into channels on targa bar. Snap bow flap to the rear bow. Snap top to studs on vehicle. Lock support bow into position.

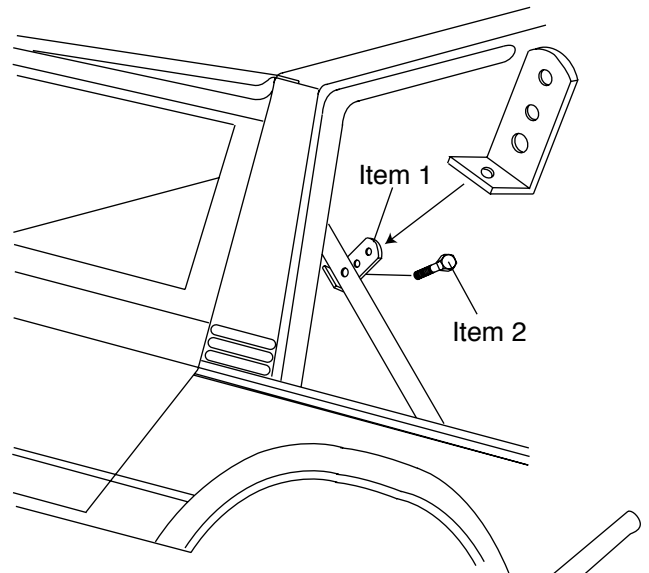

Figure 1

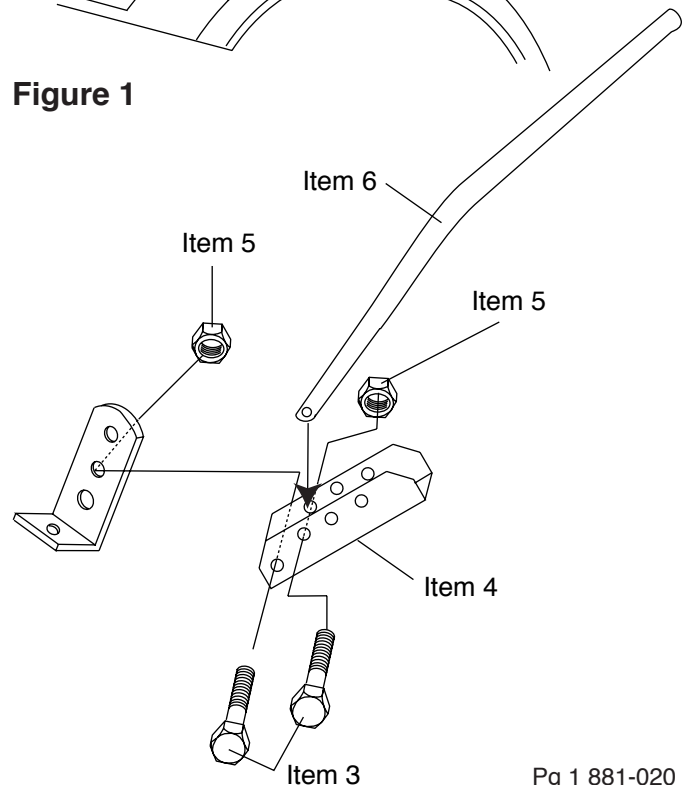

Figure 2

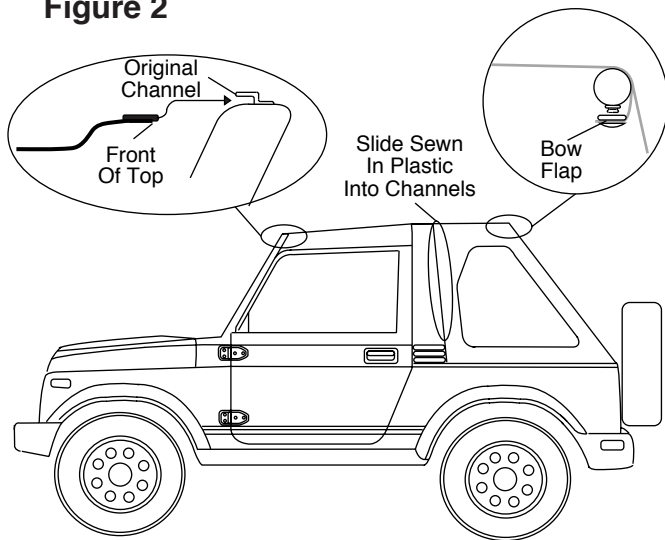
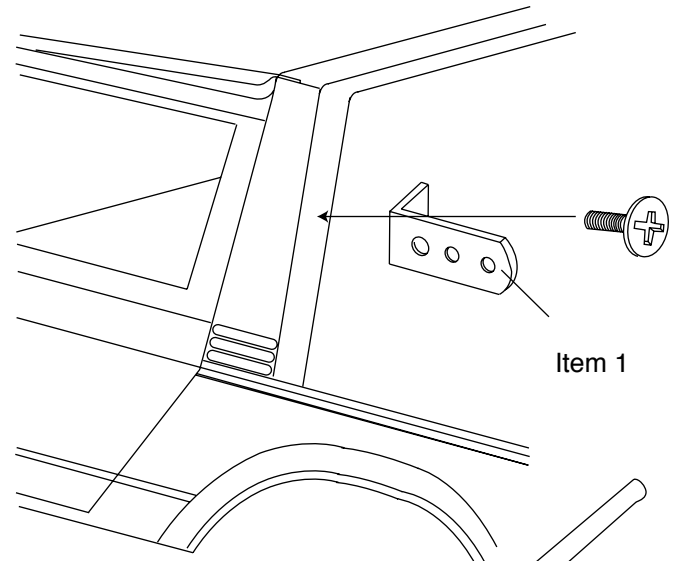

Figure 3



Installation Procedures For Vehicles With No Roll Bar

Step 1. Remove screw 39 CM (approximately 15 3/8") from top of body at rear of targa bar. Place "L" bracket (Item 1) over hole and secure to vehicle with original screw. Repeat for the other side. See figure 3.

Step 2. Place 1/4-20 x 1 1/2 hex bolt (Item 3) through off set holes in release bracket (Item 4) and through upper hole in "L" bracket. Secure with 1/4-20 lock nut (Item 5). Do not over tighten as these items need to pivot. Place 1/4-20 x 1 1/2" hex bolt (Item 3) through one side of release bracket (Item 4) support bow (Item 6) and the other side of release bracket. Secure with 1/4-20 lock nut (Item 5). Again these items need to pivot so do not over tighten. Repeat for the other side. See figure 1.

Step 3. Slip front edge of top into channel on top of windshield frame. See figure 2. Flip top over vehicle and rear support bow. Slide sewn in plastic on side panels into channels on targa bar. Snap bow flap to the rear bow. Snap top to studs on vehicle. Lock support bow into position.

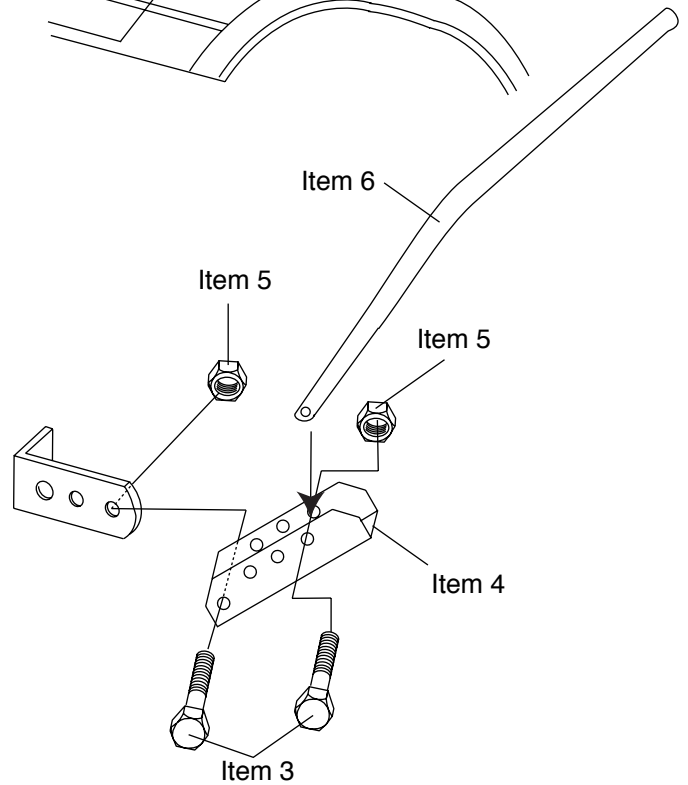

Rolling Up Rear Curtain. Before rolling up rear curtain, clean window with a mild non-detergent soap and water. If window is not clean, dirt will scratch it reducing top life. You may want to use a soft cloth between window and retaining straps to prevent marring of the glass. To roll up the rear curtain, unfasten snaps from tailgate and unzip rear curtain. Roll up rear curtain and secure with retaining straps.

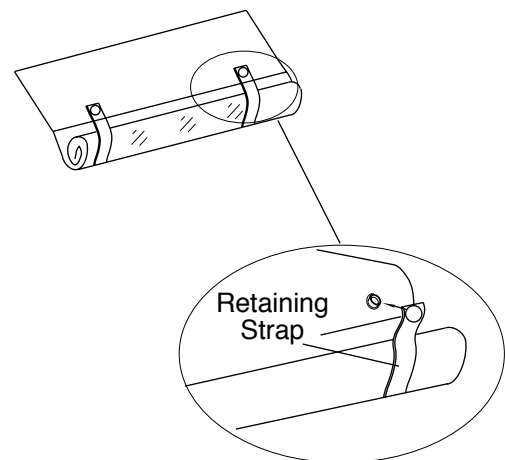

CARE INSTRUCTIONS

Convertible tops and accessories require special care if you want to get the maximum usage and enjoyment from them. The following recommendations, if followed carefully, can extend the life of your top or accessory.

1. Hand wash using a mild non-detergent soap such as Ivory. Use a nonabrasive cloth or sponge. Rinse thoroughly.
2. **DO NOT** wash in direct sunlight and avoid automatic car washes.
3. When your top is clean, we recommend using "RAGG TOPP" or "303 Protectant" on both the vinyl top and windows. This product contains a sunscreen that helps protect from the sun's damaging rays. Stay away from products containing alcohol as it will cause the fabric and windows to lose their elasticity, thus reducing the life of your top or accessory. If you are unable to locate "RAGG TOPP" Please call 1-800-377-4700 for a distributor near you or go online to www.wolfsteins.com. For "303 Protectant", please call 1-800-223-4303 for a distributor near you.
4. Direct sunlight and heat are the biggest enemies of the windows. Park in the shade whenever possible. If you must park in the sunlight, rotate the direction that you park every few days so all windows get even exposure.
5. Our tops are designed so that you may roll up and/or store the rear curtain and side curtains. To prevent scratching of the windows, be sure that windows are completely clean and free of dust particles. Even a little dirt will badly scratch the windows. You may want to use a soft cloth when rolling up or storing your windows. Heat may build up on rolled up windows, so be sure to unroll them frequently. If you roll up the windows at the beginning of summer and leave them, they may be ruined by fall.
6. **DO NOT** open or roll up windows at temperatures below 45 degrees F. This could cause them to crack or break.

WARRANTY INFORMATION:

Specialty Top Co. warrants to the original purchaser of any product it manufactures, that the product will be free of defects in material or workmanship for a period of 90 days from date of purchase. Such obligations under this warranty shall be limited to the **repair or replacement**, at Specialty's discretion, of any assembly or parts which upon examination by Specialty Top Co. proves to be defective. All defective items must be returned with proof of purchase to Specialty Top Co., 200 East 64th Avenue, Denver, Colorado 80221, freight prepaid. This warranty does not cover damage resulting from abuse, misuse, alteration, accident or damage in transit. Specialty's obligations under this warranty are limited to the aforementioned repair or replacement of warranty defects for which the return authorization has been received during the warranty period, and **SPECIALTY TOP CO. SHALL NOT BE LIABLE FOR ANY INCIDENTAL OR CONSEQUENTIAL DAMAGES ARISING FROM BREACH OF THIS OR ANY IMPLIED WARRANTY.**

Some states do not allow the exclusion or limitation of incidental or consequential damages, so the above limitation or exclusion may not apply to you. This warranty gives you specific legal rights, and you may also have other rights which may vary from state to state.

If you need assistance or further information, you may contact Specialty Top Co. at 1-866-487-9944 between the hours of 8:00 AM and 5:00 PM, Monday through Friday, Mountain Standard Time.