



SPECIALTY TOP CO.

INSTALLATION INSTRUCTIONS SCOUT II ROLL BAR TOP PART #442-050

Thank you for purchasing Specialty's Roll Bar Top for your Scout vehicle. It has been designed for great fit and long wear. Please read and follow, precisely, all installation instructions provided when installing top. Failure to do so may result in a poor fitting top and could place occupants in a potentially hazardous situation.

TOOLS REQUIRED:

1/8" DRILL BIT 5/32" DRILL BIT
#2 PHILLIPS SCREWDRIVER

PARTS LIST:

2 ea Footman Loop
4 ea #8 x 1/2 Sheet Metal Screws
3 ea Sheet Metal Screw Studs

INSTALLATION TIPS

Before you begin installing this top, here are a few tips to make installation easier.

This top should be installed where the temperature is above 72 degrees Fahrenheit. Below this temperature, the top may contract making it difficult to install.

It is normal for a top to contract and wrinkle when stored in the shipping carton. The top will relax and wrinkles will disappear within a few days of installation as fabric adjusts to shape of mounting hardware.

INSTALLATION PROCEDURES:

STEP 1. Your vehicle must be equipped with windshield slot and channel for this top to be installed properly. If you have already installed slot and channel disregard this step. If not you will have to order part #442-9440. Position windshield slot on top of windshield frame centered from side to side with the weather stripped edge toward the vertical flange on windshield frame. Place channel under slot. The channel will act as a shim to provide proper clearance between windshield frame and slot. Starting at the center mark and drill 1/8" hole using slot as a template. Secure to windshield frame with #10 x 1/2" sheet metal screw. Drill remaining holes one at a time and installing sheet metal screws as you go, making sure that gap between frame and slot remains constant from side to side. Channel should slide under slot with little resistance. Form ends of slot around windshield frame. See figure 1.

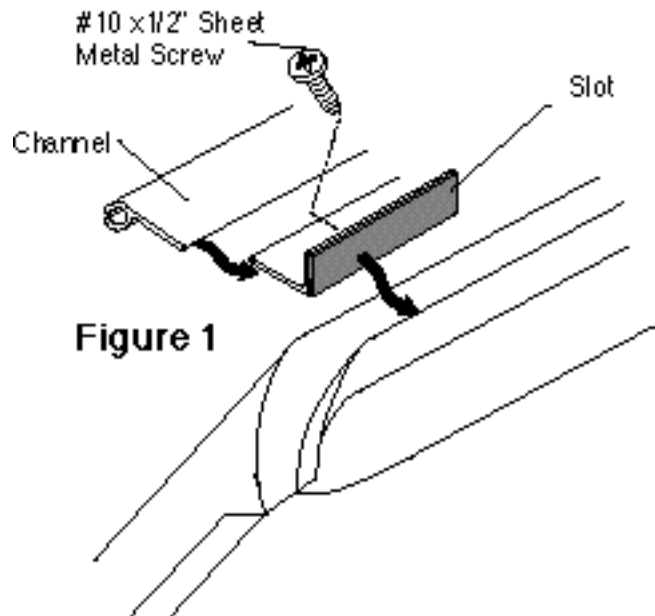

Figure 1

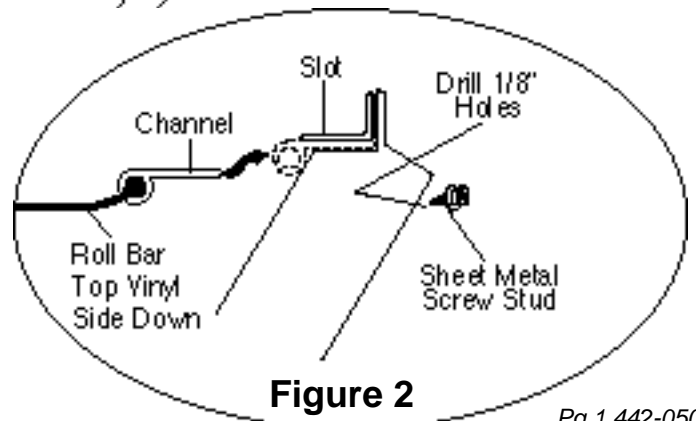

Figure 2