



SPECIALTY TOP CO.

INSTALLATION INSTRUCTIONS

Scout II PART #442-010

Thank you for purchasing Specialty's Convertible Top for your Scout vehicle. It has been designed for great fit and long wear. Please read and follow, precisely, all installation instructions provided when installing top. Failure to do so may result in a poor fitting top and could place occupants in a potentially hazardous situation.

TOOLS REQUIRED:

3/8" WRENCH	7/16" WRENCH
TAPE MEASURE	#2 PHILLIPS SCREWDRIVER
ELECTRIC DRILL	DRILL BITS (1/8", 9/64", 5/32",
RUBBING ALCOHOL	3/16" & 3/8")

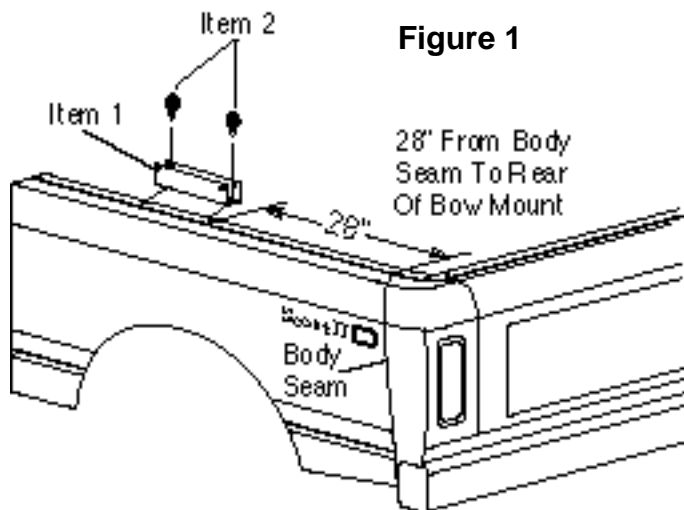

Figure 1

INSTALLATION TIPS

Before you begin installing this top, here are a few tips to make installation easier.

This top should be installed where the temperature is above 72 degrees Fahrenheit. Below this temperature, the top may contract making it difficult to install.

It is normal for a top to contract and wrinkle when stored in the shipping carton. The top will relax and wrinkles will disappear within a few days of installation as fabric adjusts to shape of mounting hardware.

INSTALLATION PROCEDURES:

On page 3 of this instruction manual there is an assembly drawing. Please refer to it for identification of parts and assembly assistance. Also refer to page 6 to assure that all parts are included in your kit.

Step 1. Bow Mount. Measure 28" from the body seam at corner and mark a line on raised level of the body. The rear of the bow mount (Item 1) will be positioned on this line. Using bow mount as a template, mark and drill 5/32" holes. Only one front and one rear hole of bow mount will be used. Secure bow mount to body with #14 x 1/2" sheet metal screws (Item 2). Repeat for the other side. See figure 1.

Step 2. Body Aluminum. Locate rear body aluminum (Item 3) just outside slight drop in body edge with the notch in body aluminum aligned with body seam. Slight bending may be required to match body contours. Using body aluminum as a template, mark and drill 1/8" holes. Secure to body with #10 x 1/2" sheet metal screw (Item 4). Butt front body aluminum (Item 5) up to rear body aluminum and secure to body using same procedure as above. Repeat for the other side. See figure 2.

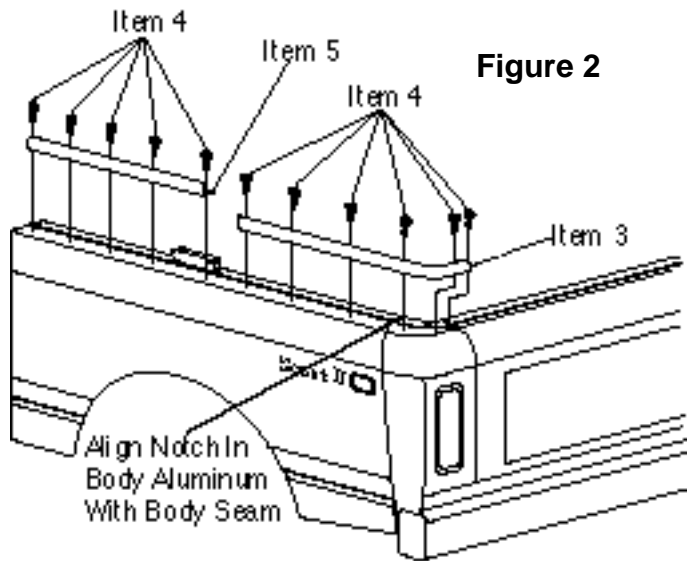

Figure 2

Step 4. Windshield Slot. Position windshield slot (Item 12) on top of windshield frame centered from side to side, and with the weather stripped edge toward the vertical flange on top of frame. Place windshield channel (Item 13) under windshield slot. The channel will act as a shim to provide proper clearance between windshield frame and windshield slot. Starting at the center, mark and drill 1/8" hole. Secure slot to flange on windshield frame with a #10 x 1/2" sheet metal screws (Item 4). Mark drill and install sheet metal screws in remaining holes following same procedure as above making sure that gap between windshield slot and windshield frame remains the same from side to side. Windshield channel should slide under windshield slot easily with little resistance. Form ends of slot around flange on windshield frame. See figure 4-A and 4-B.

Step 3. Bows. Secure bow release (Item 6) to rear set of holes in bow mount by placing 1/4-20 x 1 1/2" hex head bolt (Item 7) through one side of bow mount, bow release bracket and through other side of bow mount. Secure with 1/4-20 lock nut (Item 8). These items must pivot so do not over tighten. Repeat for the other side. Place bow sleeve (Item 9) over rear bow halves (Item 10). Place rear bow into bow release bracket. Place 1/4-20 x 1 1/2" hex head bolt (Item 7) through center hole in bow release bracket, rear bow and through other side of bow release bracket. Secure with 1/4-20 lock nut (Item 8). Again these items must pivot so do not over tighten. Place bow sleeve (Item 9) over front bow halves (Item 11). Place front bow into front holes in bow mount with large holes in front bow are facing forward. Secure to bow mount by placing 1/4-20 x 1 1/2" hex head bolt through one side of bow mount, front bow and through the other side of bow mount. Secure with 1/4-20 lock nut. Again these items must pivot so do not over tighten. Repeat for the other side. See figure 3.

Step 5. Horizontal Rods. Measure 1/2" in from side of windshield frame and 1/2" in from inside of windshield frame. Mark and drill 3/8" hole. See figure 4-A. While pulling front bow forward, place front of horizontal rod (Item 14) into hole in windshield frame. Place the rear of horizontal rods into hole in front bow. See figure 4-B and 4-D. Repeat for the other side. There is one left and one right horizontal rod. The right is painted white on the end that is placed into hole in windshield frame. Repeat for other side.

Step 6. Vertical Rods. With door closed, find position of vertical rod (Item 17) by holding it in place at rear of door frame vertical to the horizontal rod. Mark and drill 3/8" hole in body at this point. Remove 1/4" washer (Item 15) and wing nut (Item 16) from horizontal rod. Place vertical rod into hole drilled in body and over bolt on horizontal rod. Attach vertical rod to horizontal rod with washer and wing nut previously removed. Repeat for other side. Again the right side vertical rod is marked white at the end that is placed into hole in body. See figure 4-G.

Step 7. Footman Loops. Position footman loop (Item 18), at rear corner, at a forty-five degree angle to side of body. Mark and drill 1/8" holes using footman loop as a template. Secure to body with #8 x 1/2" oval head sheet metal screws (Item 19). Repeat for the other side. See figure 3.

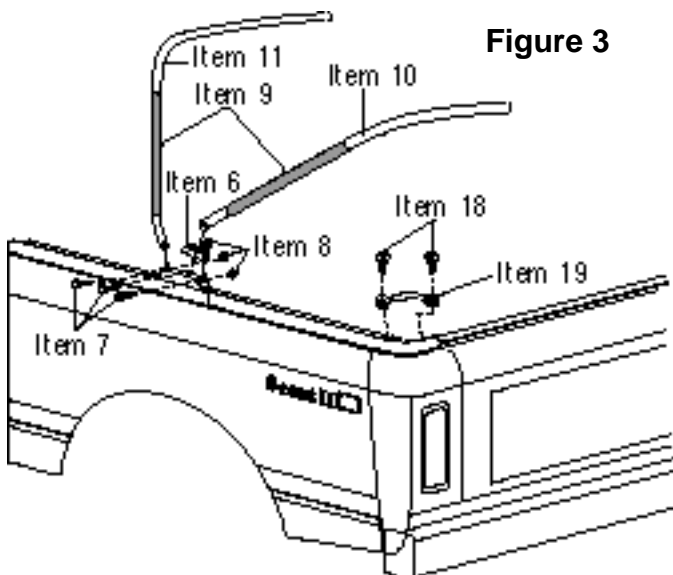
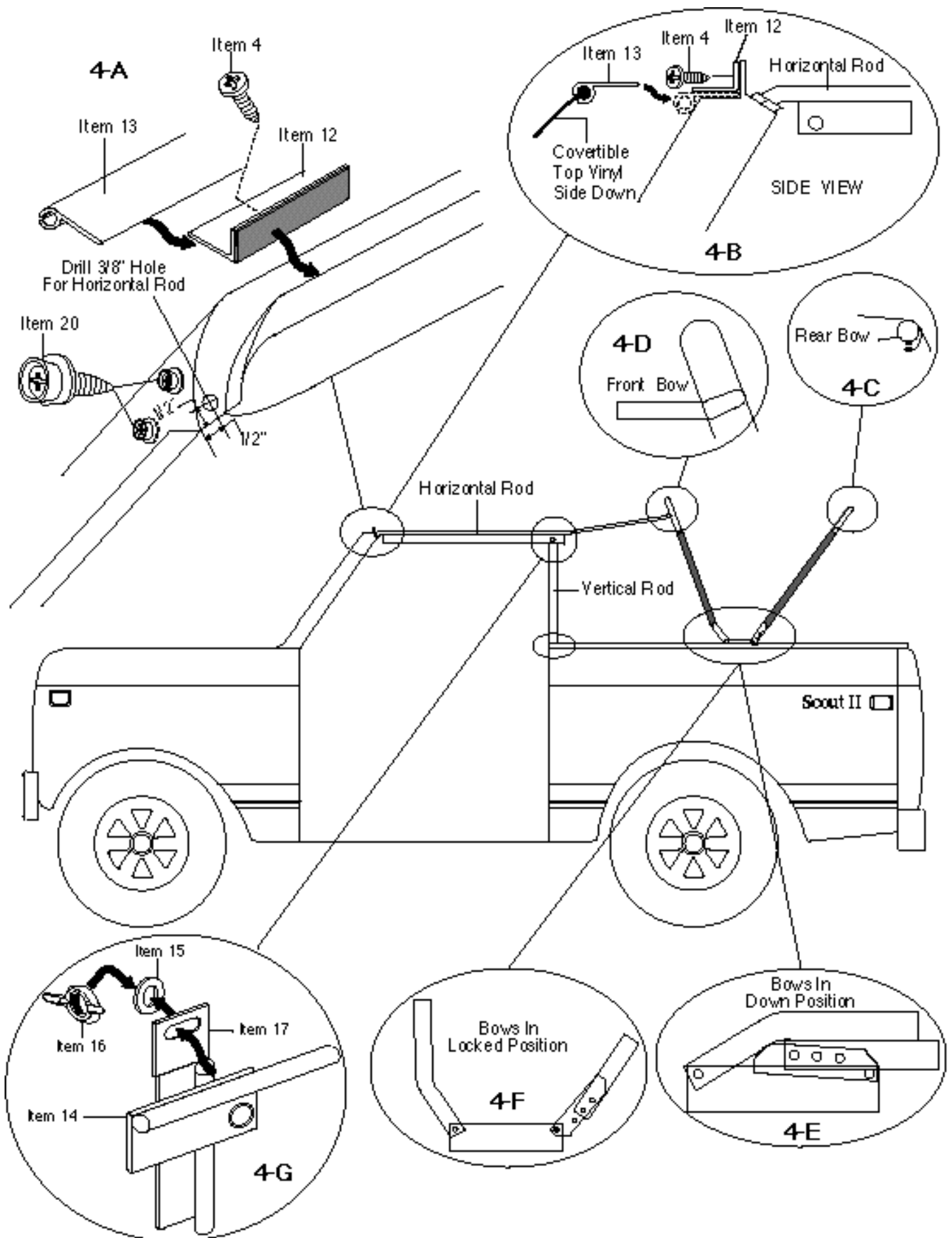

Figure 3



FABRIC INSTALLATION

Step 1. Channel Installation. Place top on hood of vehicle, vinyl side down. Slide sewn in rope (at front of top) into windshield channel (item 13). See figure 4-B. Slip channel under windshield slot. Flip top up and over bows. Snap rear bow flap to rear bow. See figure 4-C.

Step 2. Snap Stud Installation, Tailgate. Lock rear bow into position. See figure 4-F. zip rear curtain zippers about half way closed. Pull down on center snap on rear curtain until snap is approximately 1/2" down from top of tailgate. Mark and drill 1/8" hole at this point. Install 3/8" sheet metal screw stud (Item 20). See figure 5. If you experience trouble installing the sheet metal screw stud you may need to drill a 9/64" hole to make installation easier. Snap top to stud. Continue installing screw studs, pulling down and to the side, alternating left to right after each stud installation and making sure that you remain parallel with top of tailgate. Snap top to snap studs as you go. One stud will be installed on the body on each side of the tailgate. This stud will be approximately 3/4" from tailgate edge.

Step 3. Stud Installation, Body Aluminum. Starting at rear corners mark and drill 3/16" holes for #10-32 machine screw studs (Item 21). Pull down and to the

rear on side panel to find location for each stud. Install #10-32 machine screw studs (Item 21) in body aluminum and secure with #10-32 hex nut (Item 22). See figure 5. Snap top to stud. Continue installing screw studs, rear to front, pulling down on side panel to remove wrinkle as you install each stud. Alternate from left to right side of vehicle after each stud installation. Snap top to snap studs as you go. Making sure that rear bow is in the locked position, thread buckle straps through footman loops footman loops. Tighten only enough to hold rear bow in place. See figure 5. If over tightened, it could cause top to tear or strap to be pulled from top. Close zippers on both sides of rear curtain.

Step 5. Horizontal And Vertical Flaps. Wrap vertical rod flap around vertical rod and press hook and loop together. Wrap horizontal rod flap around horizontal rod and press hook and loop together.

Step 6. Snap Stud At Windshield Corner. Locate for snap stud (Item 20) by pulling forward and down on front of convertible top. Mark and drill 1/8" holes. Install 3/8" sheet metal screw studs and snap top to studs. Repeat for the other side. See figure 4-A.

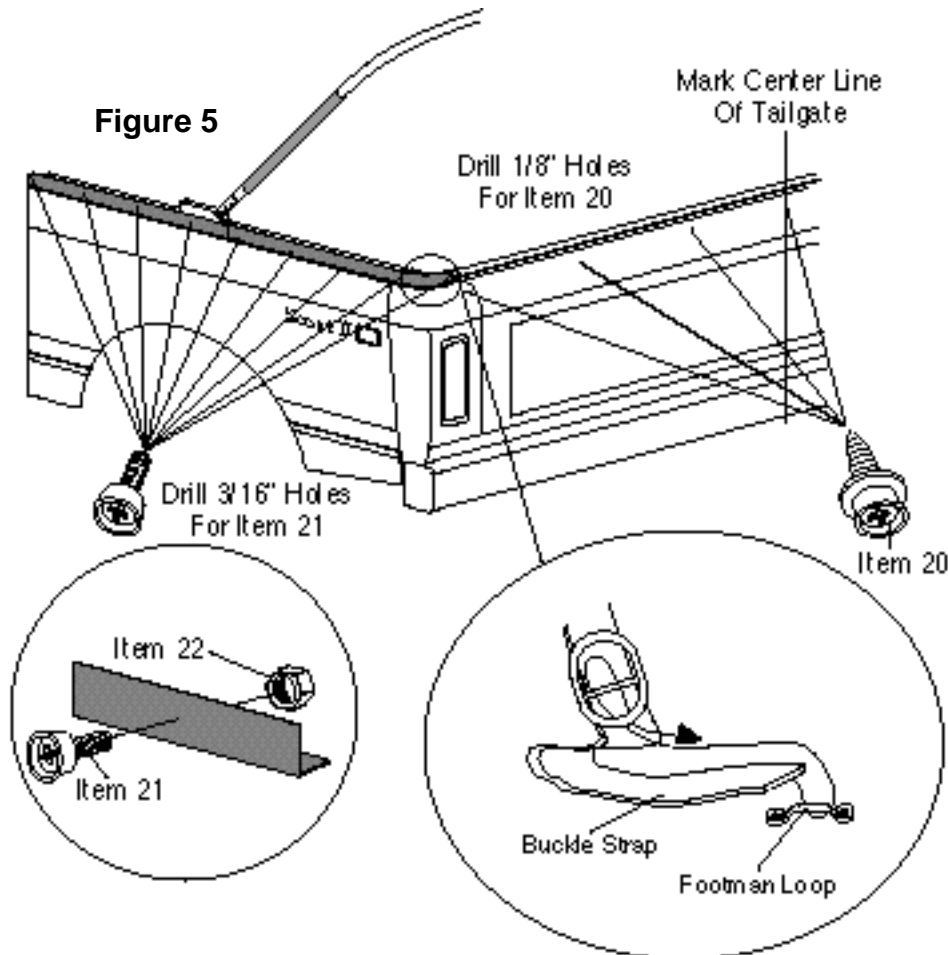

Rolling Up Side Panels. It is possible to roll up your side panels and rear curtain to provide more ventilation in your vehicle. Prior to rolling up side panels or rear curtain you must first make sure that windows are clean. If not properly cleaned, dirt will scratch them reducing the life of your top. It is also recommended that you use a soft cloth between the windows and the retaining straps to prevent them from marring the glass. To clean the windows, wash them with a mild non-detergent soap and water. To roll up side panels first unzip rear curtain and unlock rear bow. Unfasten side panel from body aluminum, roll up side panel and secure with retaining strap. See figure 6. Lock rear bow and tighten buckle strap to retain tension on convertible top. Follow same procedure to roll up rear curtain. You may roll up both side panels and rear curtain if you wish.

Figure 6

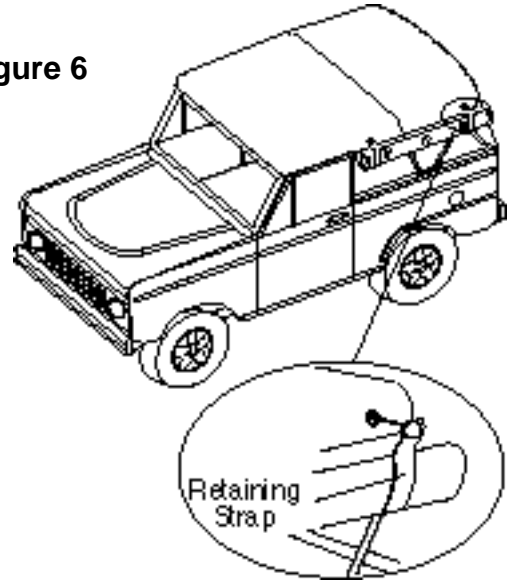

FOLDING INSTRUCTIONS

Step 1. Unlock rear bow and unfasten snaps in top from studs in body aluminum and tailgate. Lift side panels and fold on top of bows.

Step 2. Lift rear curtain and fold on top of side panels (on top of bows).

Step 3. Remove horizontal and vertical rods. Fold front of top to the rear.

Step 4. As you pull the front of top to the rear of vehicle fold as you go until you have it neatly folded at the tailgate. A convertible boot is available from your dealer to enclose your top preventing it from the dirty while in the down position. If you intend to leave the top down for an extended period of time it is recommended that you place a soft cloth between the widows and vinyl material to prevent window discoloring.

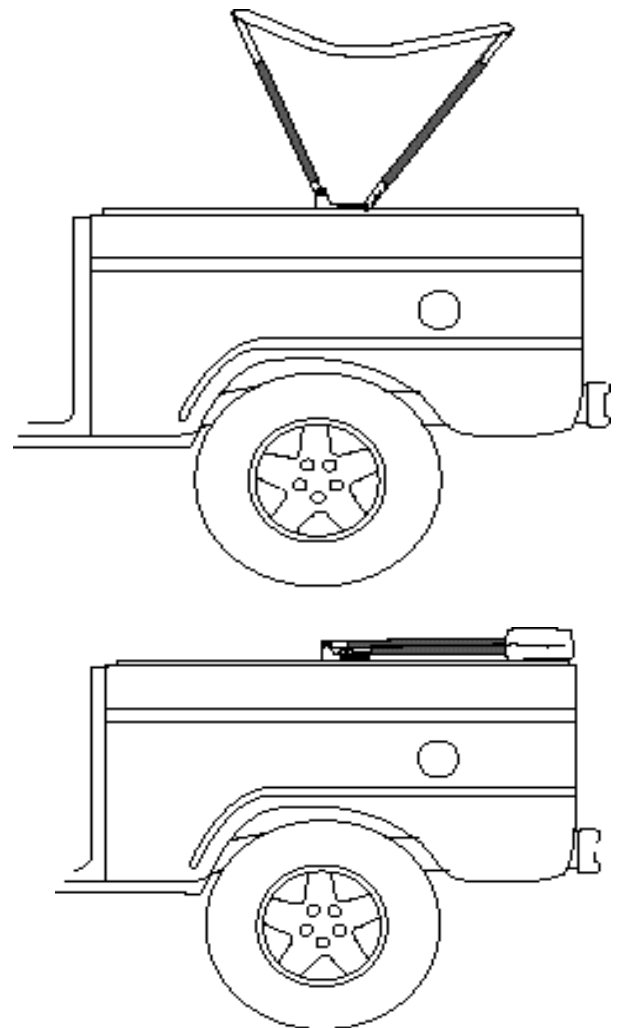
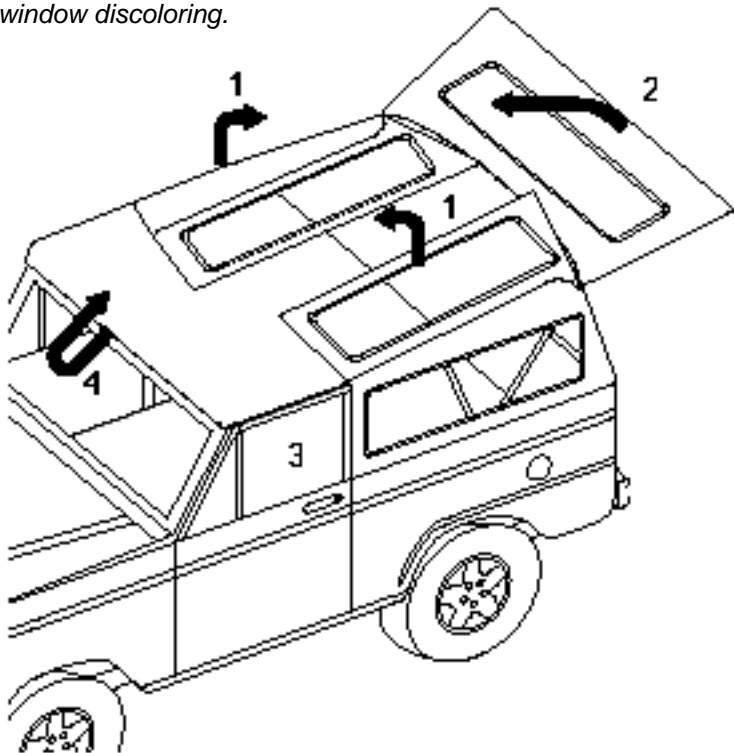

Parts Identification And Requirements

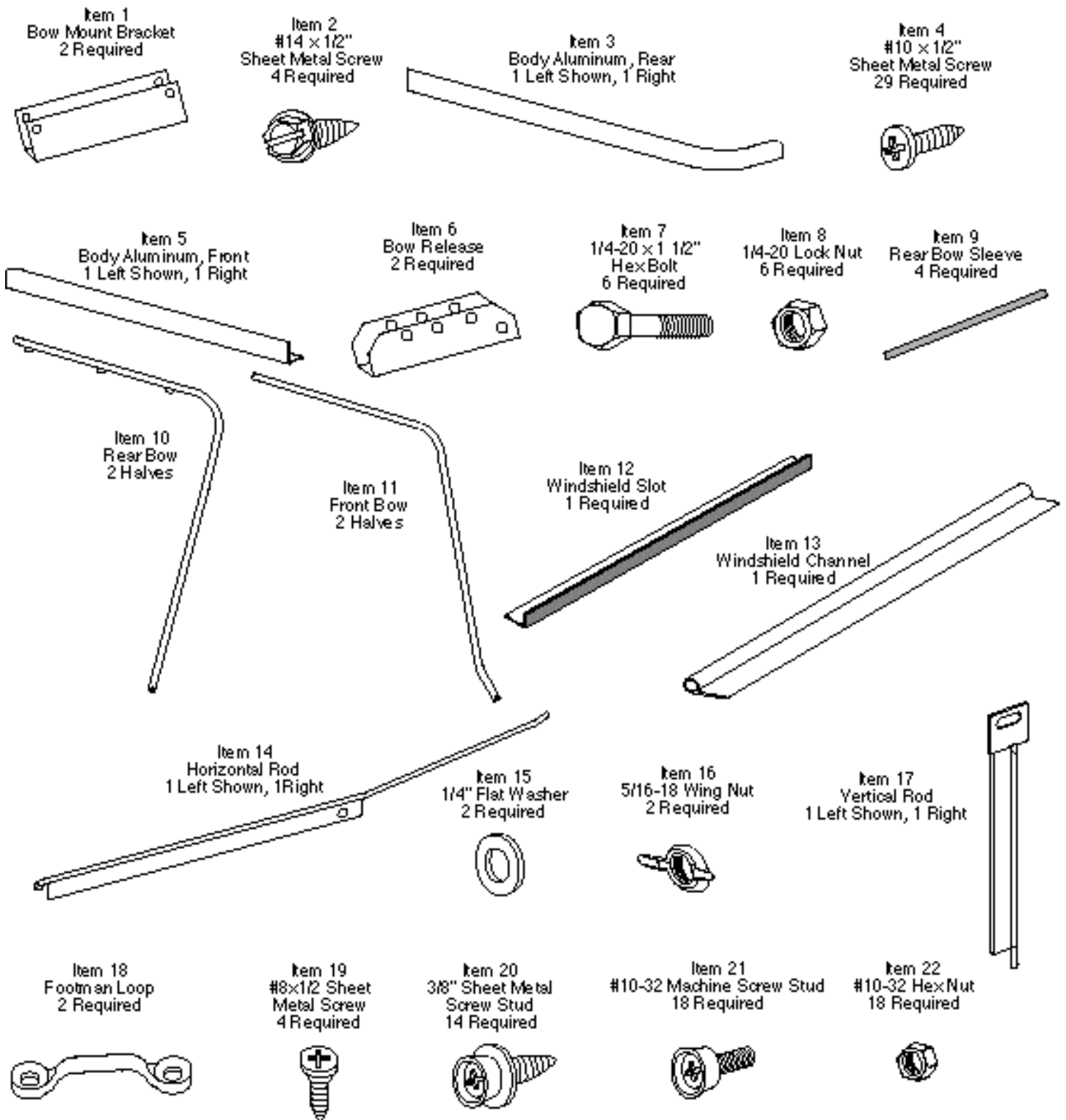

CARE INSTRUCTIONS

Convertible tops and accessories require special care if you want to get the maximum usage and enjoyment from them. The following recommendations, if followed carefully, can extend the life of your top or accessory.

1. Hand wash using a mild non-detergent soap such as Ivory. Use a nonabrasive cloth or sponge. Rinse thoroughly.
2. **DO NOT** wash in direct sunlight and avoid automatic car washes.
3. When your top is clean, we recommend using "303 Protectant" on both the vinyl top and windows. This product contains a sunscreen that helps protect from the sun's damaging rays. Stay away from products containing alcohol as it will cause the fabric and windows to lose their elasticity, thus reducing the life of your top or accessory. If you are unable to locate "303 Protectant", please call 1-800-223-4303 for a distributor near you.
4. Direct sunlight and heat are the biggest enemies of the windows. Park in the shade whenever possible. If you must park in the sunlight, rotate the direction that you park every few days so all windows get even exposure.
5. Our tops are designed so that you may roll up and/or store the rear curtain and side curtains. To prevent scratching of the windows, be sure that windows are completely clean and free of dust particles. Even a little dirt will badly scratch the windows. You may want to use a soft cloth when rolling up or storing your windows. Heat may build up on rolled up windows, so be sure to unroll them frequently. If you roll up the windows at the beginning of summer and leave them, they may be ruined by fall.
6. **DO NOT** open or roll up windows at temperatures below 45 degrees F. This could cause them to crack or break.
7. **NEVER** use ice scrapers or snow brushes on vinyl windows.

WARRANTY INFORMATION:

Specialty Top Co. manufacturing warrants to the original purchaser of any product it manufactures, that the product will be free of defects in material or workmanship for a period of 90 days from date of purchase. Such obligations under this warranty shall be limited to the **repair or replacement**, at Specialty's discretion, of any assembly or parts which upon examination by Specialty Top Co. proves to be defective. All defective items must be returned with proof of purchase to Specialty Top Co. Manufacturing, 200 East 64th Avenue, Denver, Colorado 80221, freight prepaid. This warranty does not cover damage resulting from abuse, misuse, alteration, accident or damage in transit. Specialty's obligations under this warranty are limited to the aforementioned repair or replacement of warranty defects for which the return authorization has been received during the warranty period, and **SPECIALTY TOP CO. SHALL NOT BE LIABLE FOR ANY INCIDENTAL OR CONSEQUENTIAL DAMAGES ARISING FROM BREACH OF THIS OR ANY IMPLIED WARRANTY.**

Some states do not allow the exclusion or limitation of incidental or consequential damages, so the above limitation or exclusion may not apply to you. This warranty gives you specific legal rights, and you may also have other rights which may vary from state to state.

If you need assistance or further information, you may contact Specialty Top Co. at 1-866-487-9944 between the hours of 8:00 AM and 5:00 PM, Monday through Friday, Mountain Standard Time.