



# SPECIALTY TOP CO.

## INSTALLATION INSTRUCTIONS BRONCO 1978-1979 PART #332-055

Thank you for purchasing Specialty's Curtain/Tonneau for your Bronco. It has been designed for great fit and long wear. Please read and follow, precisely, all installation instructions provided when installing top. Failure to do so may result in a poor fitting top and could place occupants in a potentially hazardous situation.

### TOOLS REQUIRED:

7/16" WRENCH      ELECTRIC DRILL  
8' TAPE MEASURE    1/8" & 3/16" DRILL BITS  
#2 PHILLIPS SCREWDRIVER

### INSTALLATION TIPS

Before you begin installing this top, here are a few tips to make installation easier.

This top should be installed where the temperature is above 72 degrees Fahrenheit. Below this temperature, the top may contract making it difficult to install.

It is normal for a top to contract and wrinkle when stored in the shipping carton. The top will relax and wrinkles will disappear within a few days of installation as fabric adjusts to shape of mounting hardware.

### INSTALLATION PROCEDURES:

Refer to page 4 to assure that all parts are included in your kit.

**Step 1. Body Aluminum.** Locate rear body aluminum (Item 1) just outside slight drop in body edge and 2 1/2" to the rear of notch in body. Using body aluminum as a template, mark and drill 1/8" holes. Secure to body with #10 x 1/2" sheet metal screws (Item 2). Butt front body aluminum (Item 3) up to rear body aluminum. Mark and drill 1/8" holes using front body aluminum as a template. Secure to body with #10 x 1/2" sheet metal screws (Item 2). See figures 1 and 2.

**Step 2. Tailgate aluminum.** Butt both pieces of tailgate aluminum (Items 4 & 5) together on top edge of tailgate. Center from left to right and 1/2" from the rear of the body aluminum to the rear edge of tailgate aluminum. Making sure that tailgate aluminum is parallel with tailgate, mark and drill 1/8" holes using tailgate aluminum as a template. Secure to tailgate with #10 x 1/2" sheet metal screws (Item 2). See figure 1.

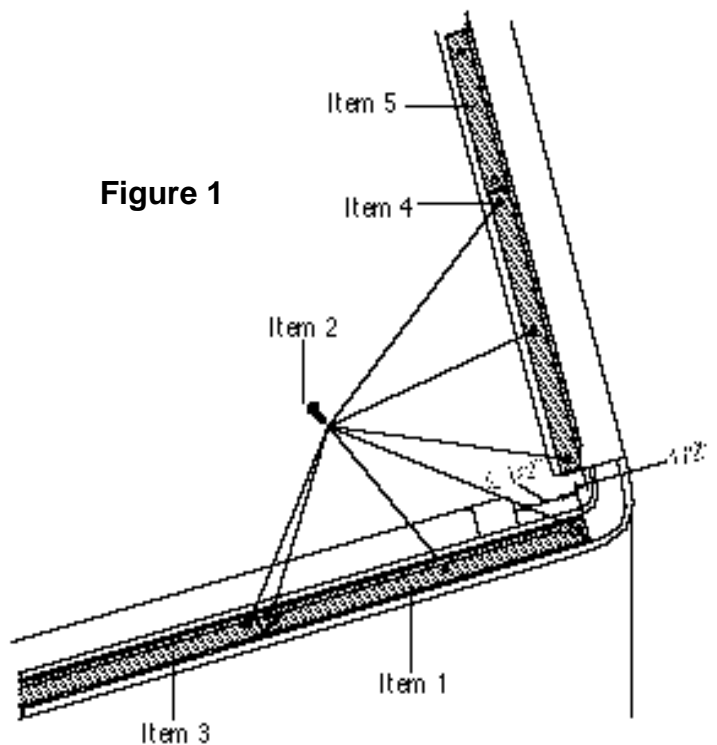
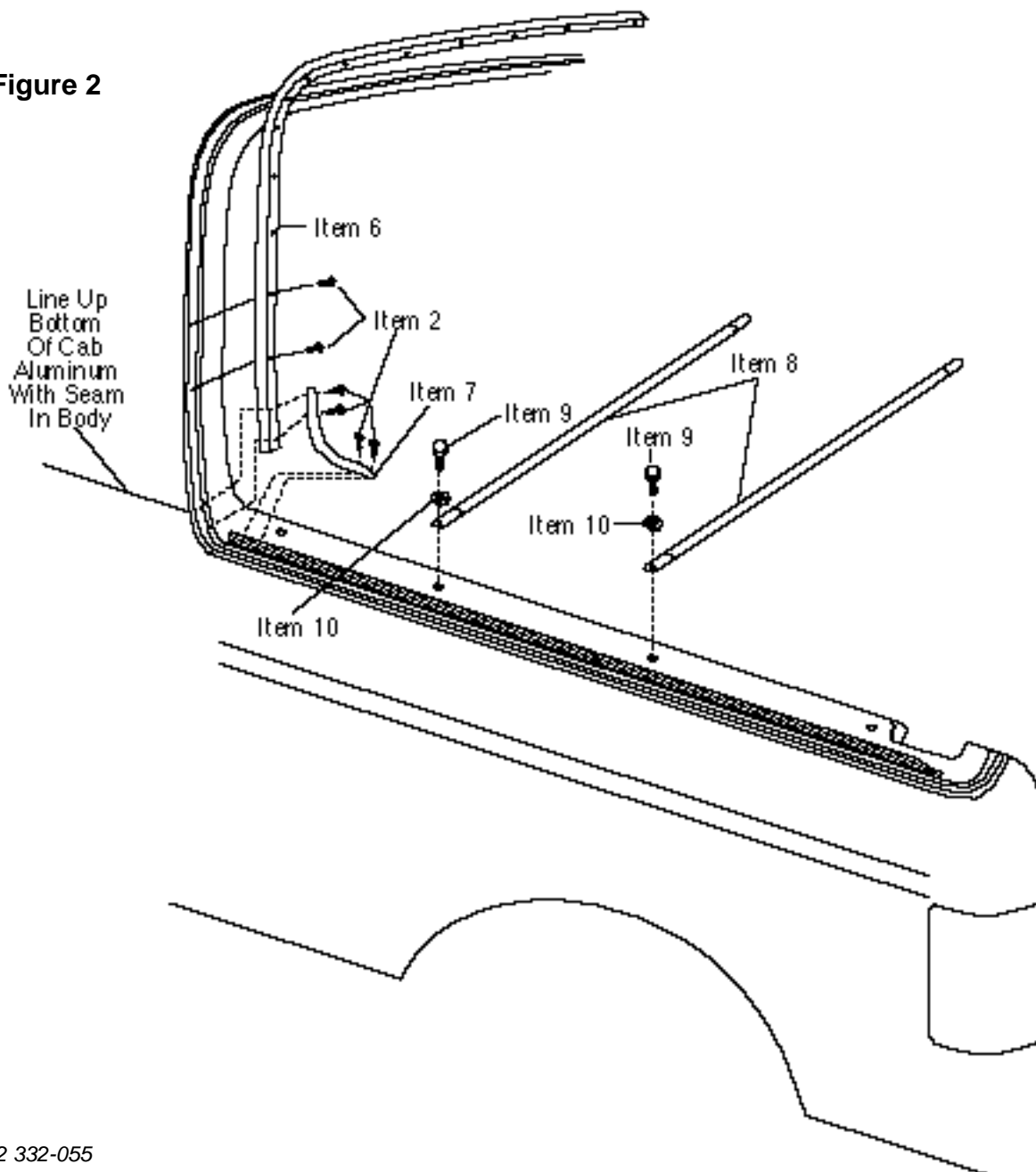

Figure 1

**Step 3. Cab Aluminum.** Position bottom of cab aluminum (Item 6) even with seam in body at rear of cab. Starting at the bottom mark and drill 1/8" holes using cab aluminum as a template. Secure to cab with #10 x 1/2" sheet metal screw (Item 2). Drill and install one screw at a time making sure that cab aluminum follows the contour of cab. Slight bending of cab aluminum may be necessary. Butt cab aluminum pieces together at center of cab. Mark, drill and install screws using same procedure. Make sure that cab aluminum will follow contour of cab before drilling. One side of cab aluminum may require trimming prior to final installation for a proper fit. Place cab corner piece (Item 7) at rear corner of cab. Using cab corners as templates mark and drill 1/8" holes. Secure to body with #10 x 1/2" sheet metal screws (Item 2). See figure 2.

**Step 4. Bows.** Slide bow halves together (Item 8). Line up holes in bows with center set of threaded plates on top of body. Secure bows to body with 1/4-20 x 3/4" hex bolt (Item 9) through 1/4" flat washer (item 10). See figure 2.

Figure 2



**Step 5. Top Installation.** Measure 3" to the right of center split in cab aluminum and 1/4" from the rear edge of cab aluminum. Mark and drill 3/16" hole. Place sheet metal screw stud (Item 11) into hole and tighten. Find center of the cab curtain and secure snap, to the right of center, to stud just installed. Install remaining screw studs on cab aluminum alternating from left to right. Pull on the top until smooth. Mark for best hole location using vinyl top as a guide. Install each stud and snap into position until all studs are in place on cab aluminum. Drill 3/16" holes for machine screw studs (Item 1) in cab corner piece. Secure with #10 -32 hex nuts (Item 13). Place tonneau over bows and snap to last stud installed for the cab curtain. Zip tonneau to cab curtain. Find center of tailgate aluminum and mark a line. Pull center snap on rear curtain down to meet center line on tailgate aluminum. Mark and drill 3/16" hole. Install machine screw stud and snap center snap on the top to the stud. Continue installing studs alternating from left to right and pulling on rear of tonneau until smooth when finding stud positions. See figure 3. Install remaining snap studs to body aluminum using same procedure as above Pull tab at rear corners of tonneau down and to the center of vehicle to find best position for sheet metal screw stud. Mark and drill 1/8" hole and install sheet metal screw stud. Snap tonneau to stud. See figure 3

**Step 6. Footman Loops.** Install footman loop (Item 14) behind the seats on the floor. To find the location for footman loops find hold down straps at bottom of cab curtain and pull down towards the floor. Place strap around footman loop and mark location. Using footman loop as a template mark and drill 1/8" holes. Secure footman loop to floor with #8 x 1/2" sheet metal screws (Item 15). See figure

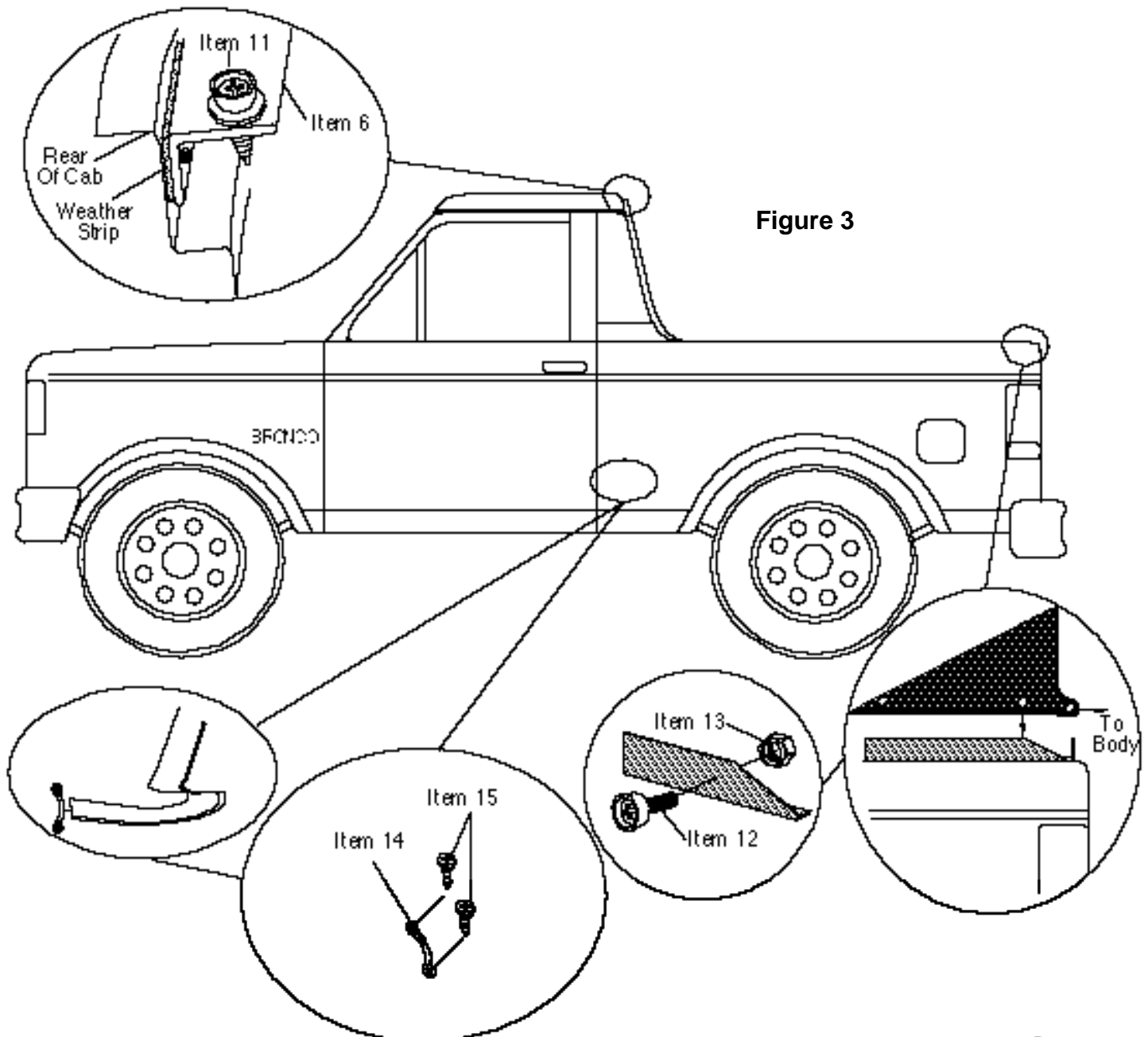

# PARTS IDENTIFICATION

Item 1  
Rear Body Aluminum  
1 Left Shown, 1 Right

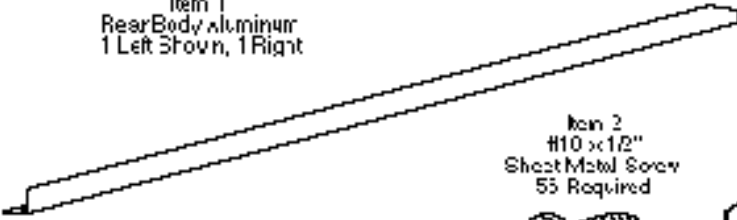

Item 3  
Front Body Aluminum  
1 Left Shown, 1 Right

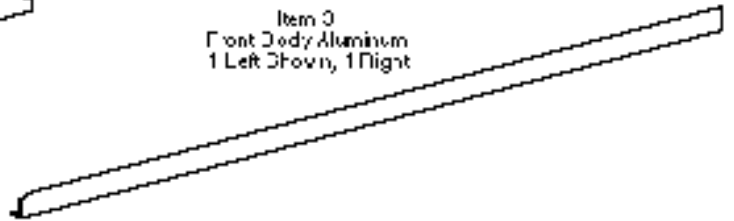

Item 2  
#10 x 1/2"  
Sheet Metal Screw  
55 Required



Item 4  
Tailgate Aluminum  
1 Left

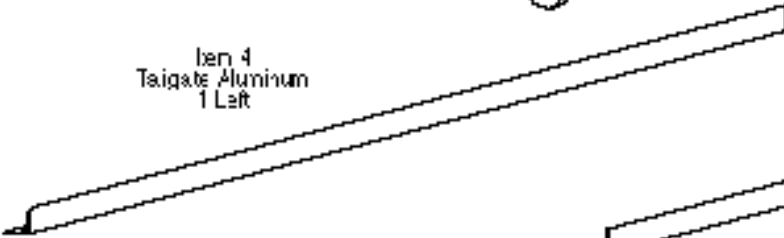

Item 5  
Tailgate Aluminum  
1 Right

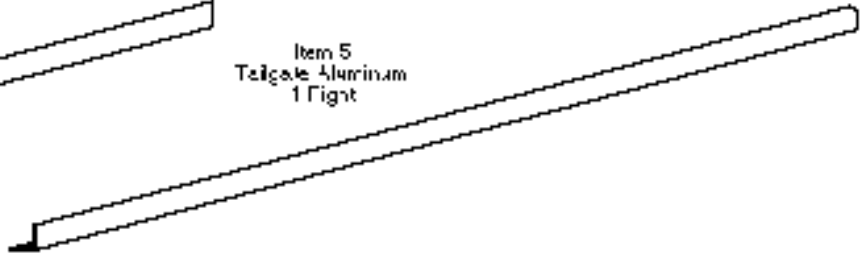

Item 6  
Cab Aluminum  
1 Left Shown, 1 Right

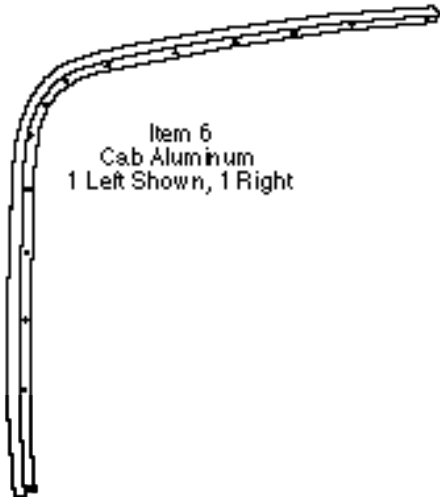

Item 7  
Cab Corner  
2 Required



Item 8  
Bow  
1 Left Shown, 1 Right

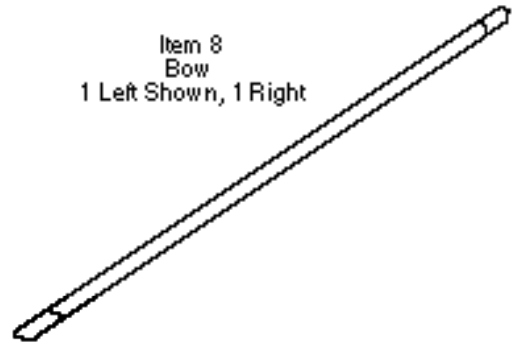

Item 9  
1/4-20 x 3/4"  
Hex Bolt  
4 Required



Item 10  
1/4" Flat Washer  
4 Required



Item 11  
Sheet Metal Screw Stud  
18 Required



Item 12  
#10-32 Machine Screw Stud  
31 Required



Item 13  
#10-32 Hex Nut  
31 Required



Item 14  
Footman Loop  
2 Required



Item 15  
#8 x 1/2" Oval Head  
Sheet Metal Screw  
4 Required



## **CARE INSTRUCTIONS**

*Convertible tops and accessories require special care if you want to get the maximum usage and enjoyment from them. The following recommendations, if followed carefully, can extend the life of your top or accessory.*

- 1. Hand wash using a mild non-detergent soap such as Ivory. Use a nonabrasive cloth or sponge. Rinse thoroughly.*
- 2. **DO NOT** wash in direct sunlight and avoid automatic car washes.*
- 3. When your top is clean, we recommend using "303 Protectant" on both the vinyl top and windows. This product contains a sunscreen that helps protect from the sun's damaging rays. Stay away from products containing alcohol as it will cause the fabric and windows to lose their elasticity, thus reducing the life of your top or accessory. If you are unable to locate "303 Protectant", please call 1-800-223-4303 for a distributor near you.*
- 4. Direct sunlight and heat are the biggest enemies of the windows. Park in the shade whenever possible.*
- 5. **DO NOT** open or roll up windows at temperatures below 45 degrees F. This could cause them to crack or break.*
- 6. **NEVER** use ice scrapers or snow brushes on vinyl windows.*

## **WARRANTY INFORMATION:**

*Specialty Top Co. warrants to the original purchaser of any product it manufactures, that the product will be free of defects in material or workmanship for a period of 90 days from date of purchase. Such obligations under this warranty shall be limited to the **repair or replacement**, at Specialty's discretion, of any assembly or parts which upon examination by Specialty Top Co. proves to be defective. All defective items must be returned with proof of purchase to Specialty Top Co., 200 East 64th Avenue, Denver, Colorado 80221, freight prepaid. This warranty does not cover damage resulting from abuse, misuse, alteration, accident or damage in transit. Specialty's obligations under this warranty are limited to the aforementioned repair or replacement of warranty defects for which the return authorization has been received during the warranty period, and **SPECIALTY TOP CO. SHALL NOT BE LIABLE FOR ANY INCIDENTAL OR CONSEQUENTIAL DAMAGES ARISING FROM BREACH OF THIS OR ANY IMPLIED WARRANTY.***

*Some states do not allow the exclusion or limitation of incidental or consequential damages, so the above limitation or exclusion may not apply to you. This warranty gives you specific legal rights, and you may also have other rights which may vary from state to state.*

*If you need assistance or further information, you may contact Specialty Top Co. at 1-866-487-9944 between the hours of 8:00 AM and 5:00 PM, Monday through Friday, Mountain Standard Time.*