



SPECIALTY TOP CO.

INSTALLATION INSTRUCTIONS

ROLL BAR TOP BRONCO 1966-1977 PART # 331-05X

Thank you for purchasing Specialty's Roll Bar Top for your Bronco vehicle. It has been designed for great fit and long wear. Please read and follow, precisely, all installation instructions provided when installing top. Failure to do so may result in a poor fitting top and could place occupants in a potentially hazardous situation.

TOOLS REQUIRED:

3/8" WRENCH
1/2" WRENCH
1/8" DRILL BIT
8' TAPE MEASURE
7/16" WRENCH
#2 PHILLIPS SCREWDRIVER
ELECTRIC DRILL

PARTS LIST:

Item 1 1 ea Windshield Riser
Item 2 9 ea 5/16-18 x 3/4 Hex Bolt
Item 3 9 ea 1/4 Flat Washer
Item 4 9 ea 5/16 Star Washer
Item 5 9 ea 5/16-18 Hex Nut
Item 6 1 ea Windshield Wiper Motor Bracket
Item 7 1 ea Channel
Item 8 2 ea Footman Loop
Item 9 4 ea #8 x 1/2 Sheet Metal Screw
Item 10 3 ea Sheet Metal Screw Stud

INSTALLATION TIPS

Before you begin installing this top, here are a few tips to make installation easier.

This top should be installed where the temperature is above 72 degrees Fahrenheit. Below this temperature, the top may contract making it difficult to install.

It is normal for a top to contract and wrinkle when stored in the shipping carton. The top will relax and wrinkles will disappear within a few days of installation as fabric adjusts to shape of mounting hardware.

INSTALLATION PROCEDURES:

STEP 1. Riser. If your vehicle is already equipped with a windshield riser, disregard this step. Position riser on top of windshield frame centered from side to side. Place 5/16-18 x 3/4 hex bolts (Item 2) through 1/4" flat washers (Item 3), riser, windshield frame and 5/16" star washer. Secure with 5/16-189 hex nut (Item 5). See figure 1.

STEP 2. Windshield Wiper Motor Bracket. On certain models a windshield wiper motor bracket (Item 6) may be needed to lower the wiper motor. If your vehicle does not require a windshield motor bracket or is already equipped with one, disregard this step. Remove wiper arm from motor. Remove motor from original bracket and bracket from windshield frame. Install windshield wiper motor

This parts list is for all Bronco roll bar tops. If you have ordered the roll bar top only, you will have received Items 8 through 10 only.

bracket to windshield frame using original holes. Turn motor over and install into wiper motor bracket using original fasteners. Reattach wiper arm making sure that wipers are in the correct position. See figure 1.

STEP 3. Top Installation. Slide channel (Item 7) over sewn in rope on vinyl top. Place channel into slot in riser. Flip top over roll bar. Place footman loop (Item 8) on top of body edge approximately 14" forward of tailgate. Mark and drill 1/8" holes using footman loops as a template. Secure to body with #8 x 1/2" sheet metal screws (Item 9). Repeat for the other side. Thread sewn in buckle straps through footman loops and tighten. Pull forward and down on tab at front of top. Mark for location of stud using snap as a guide. Drill 1/8" hole and install sheet metal screws stud. Secure top to stud. See figure 1.

Figure 1

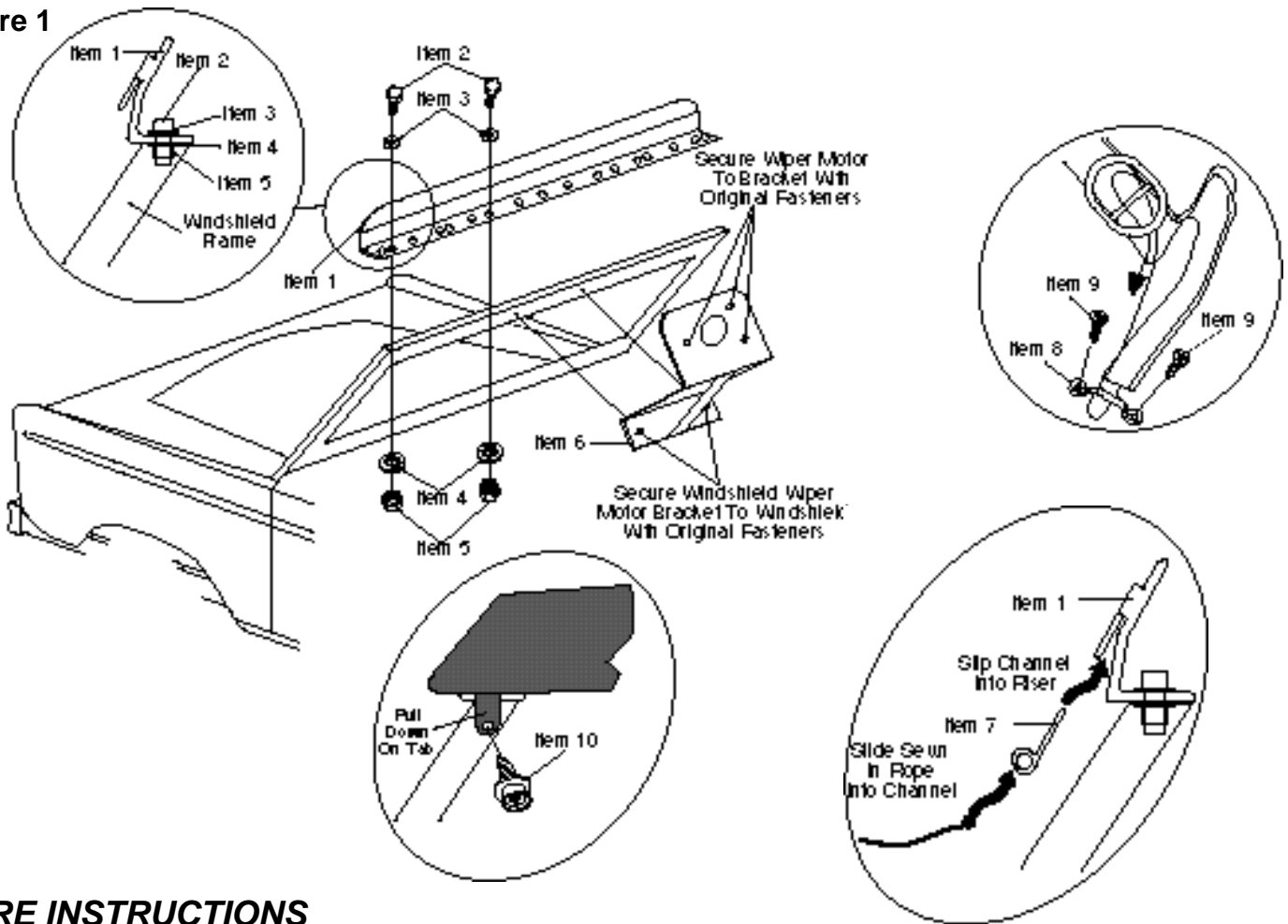

CARE INSTRUCTIONS

Convertible tops require special care if you want to get the maximum usage and enjoyment from them. The following recommendations, if followed carefully, can extend the life of your top.

1. Hand wash using a mild non-detergent soap such as Ivory. Use a nonabrasive cloth or sponge. Rinse thoroughly.
2. **DO NOT** wash in direct sunlight and avoid automatic car washes.
3. When your top is clean, we recommend using "303 Protectant" on both the vinyl top and windows. This product contains a sunscreen that helps protect from the sun's damaging rays.
4. When top is not in use, store in bag provided.

WARRANTY INFORMATION:

Specialty Top Co. manufacturing warrants to the original purchaser of any product it manufactures, that the product will be free of defects in material or workmanship for a period of 90 days from date of purchase. Such obligations under this warranty shall be limited to the **repair or replacement**, at Specialty's discretion, of any assembly or parts which upon examination by Specialty Top Co. proves to be defective. All defective items must be returned with proof of purchase to Specialty Top Co. Manufacturing, 200 East 64th Avenue, Denver, Colorado 80221, freight prepaid. This warranty does not cover damage resulting from abuse, misuse, alteration, accident or damage in transit. Specialty's obligations under this warranty are limited to the aforementioned repair or replacement of warranty defects for which the return authorization has been received during the warranty period, and **SPECIALTY TOP CO. SHALL NOT BE LIABLE FOR ANY INCIDENTAL OR CONSEQUENTIAL DAMAGES ARISING FROM BREACH OF THIS OR ANY IMPLIED WARRANTY.**

Some states do not allow the exclusion or limitation of incidental or consequential damages, so the above limitation or exclusion may not apply to you. This warranty gives you specific legal rights, and you may also have other rights which may vary from state to state.

If you need assistance or further information, you may contact Specialty Top Co. at 1-866-487-9944 between the hours of 8:00 AM and 5:00 PM, Monday through Friday, Mountain Standard Time.