



SPECIALTY TOP CO.

INSTALLATION INSTRUCTIONS TOYOTA LANDCRUISER DOORS PART #222-305

Thank you for purchasing Specialty's Doors for your vehicle. They have been designed for great fit and long wear. Please read and follow, precisely, all installation instructions provided when installing your doors. Failure to do so may result in a poor fitting doors and could place occupants in a potentially hazardous situation.

TOOLS REQUIRED:

3/8" WRENCH	7/16" WRENCH
1/2" WRENCH	13MM WRENCH
1/8" DRILL BIT	#2 PHILLIPS SCREWDRIVER
ELECTRIC DRILL	SCISSORS

Step 1. Paddle Handle. Using a pair of scissors or sharp knife, cut an "X" into fabric from corner to corner of door plate. Using the door plate as a template; cut fabric off to edges of square shape in door plate. Cut slits in fabric for screw holes and notches in door plate. Place paddle handle (Item 1) from the outside of the door through square hole in the door plate. Place #10 x 1/2" screws (Item 4) through paddle handle, slits in fabric and holes in door plate. Secure with #10 lock nuts (Item 3). Then screw inside door knob (Item 2) into hole on inside of paddle handle. Repeat for the other side. See figure 1.

Step 2. Door Striker. You will need to replace the original door strikers on your vehicle. **CAUTION:** Do not remove both of the bolts holding the striker at the same time, as this will cause the backing plate inside of the door post to fall to the bottom of the door post. This will make the backing plate almost impossible to retrieve. The proper technique is to remove one bolt, loosen the other bolt, pivot the striker so that the hole for the bolt which was removed is exposed, and reinstall that bolt. Then remove the other bolt and the striker. To install the new striker (Item 6), start the new bolt (Item 5) through the striker and into the backing plate inside of the door post, remove the remaining old bolt, pivot the striker into place, and install the other new bolt. Both bolts may be tightened at this time. Repeat for other side. You may have to install the door striker shims (Item 7) later in order to make the door latch properly. Use the same technique to do this. See figure 2.

CUT SLITS FOR
SCREWS, NOTCHES AND PADDLE HANDLE

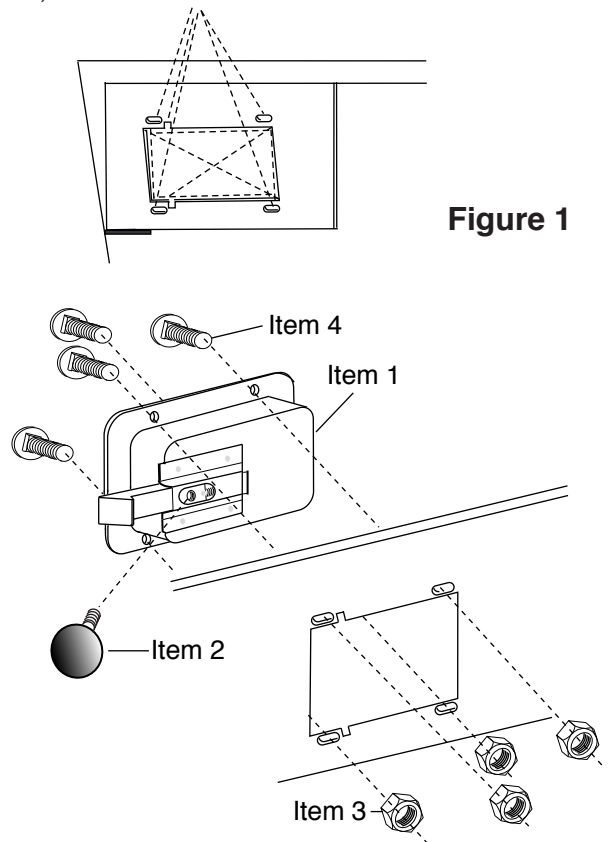

Figure 1

Passenger Side Shown

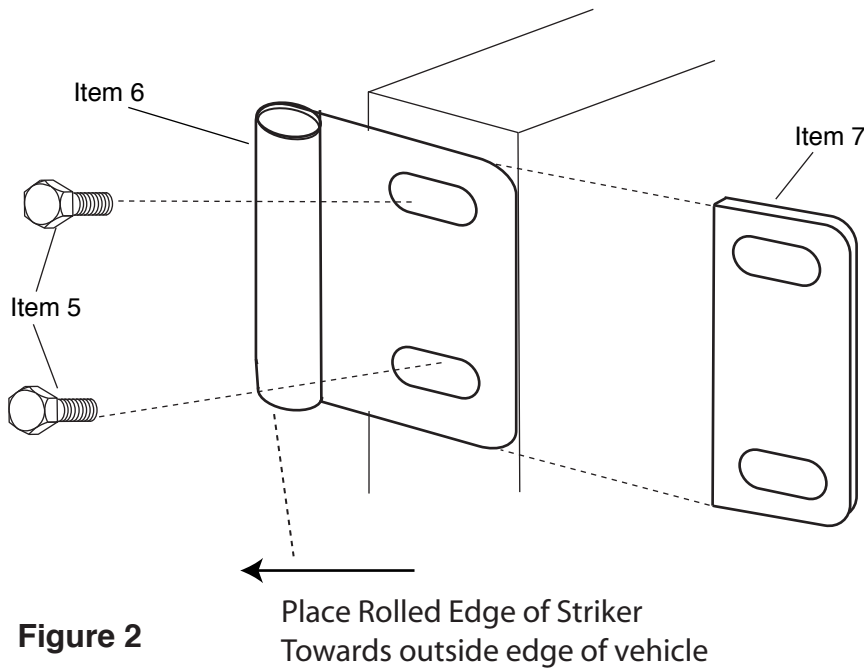

Figure 2

Place Rolled Edge of Striker
Towards outside edge of vehicle

Step 3. Fitting Door In Opening. Each door has two hinge hooks on the lower half of the door, which fit into the body portion of the original equipment hinges for the hard doors. If you have these hinges on your vehicle, you will need to drive out the hinge pins and separate the body hinges from the door hinges. **If you do not have these hinges, you will need them or an STC hinge kit (part number 222-326) which is not furnished with this door kit. The STC hinge kit contains a set of body hinges for these soft doors and the bolts to install them.** Insert the hinge hooks into the body hinges. Close the door and check the fit of the paddle handle latch to the striker. The latch should just clear the flat portion of the striker and should latch solidly against the rolled portion of the striker. The striker can be moved in or out by loosening the mounting bolts and sliding the striker plate in or out as needed. If there is too much clearance between the end of the latch and the flat part of the striker, you may need to install the striker plate shims (Item 7) between the door post and the striker plate. See figure 2 and step 2. You can also adjust the position of the latch in relation to the flat part of the striker by loosening the bolts which attach the paddle handle to the door and sliding the paddle handle towards the front or the rear of the vehicle. This adjustment is for a minor distance. Slide the pegs on the upper half of the door into the tubes on the lower half of the door. Make sure that they are fully seated into the tubes. Press the hook and loop together at the outside of the door. Due to inconsistencies in manufacturing of the vehicle and door frames some minor bending of the door may be necessary to obtain the proper fit.

WARRANTY INFORMATION:

Specialty Top Co. warrants to the original purchaser of any product it manufactures, that the product will be free of defects in material or workmanship for a period of 90 days from date of purchase. Such obligations under this warranty shall be limited to the repair or replacement, at Specialty's discretion, of any assembly or parts which upon examination by Specialty Top Co. proves to be defective. All defective items must be returned with proof of purchase to Specialty Top Co., 200 East 64th Avenue, Denver, Colorado 80221, freight prepaid. This warranty does not cover damage resulting from abuse, misuse, alteration, accident or damage in transit. Specialty's obligations under this warranty are limited to the aforementioned repair or replacement of warranty defects for which the return authorization has been received during the warranty period, and **SPECIALTY TOP CO. SHALL NOT BE LIABLE FOR ANY INCIDENTAL OR CONSEQUENTIAL DAMAGES ARISING FROM BREACH OF THIS OR ANY IMPLIED WARRANTY.**

Some states do not allow the exclusion or limitation of incidental or consequential damages, so the above limitation or exclusion may not apply to you. This warranty gives you specific legal rights, and you may also have other rights which may vary from state to state.

If you need assistance or further information, you may contact Specialty Top Co. at 1-866-487-9944 between the hours of 8:00 AM and 5:00 PM, Monday through Friday, Mountain Standard Time.

DOOR ASSEMBLY PARTS LIST

Item 1
Paddle Handle
2

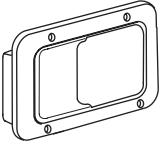

Item 2
Paddle Handle
Inside Knob
2



Item 3
#10-24 Lock Nut
8



Item 4
#10-24 X 1/2"
Phillips Screw
8



Item 5
M8x1.25x16MM
Hex Bolt
4



Item 6
Door Striker
2

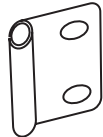

Item 7
Door Striker Shim
2



CARE INSTRUCTIONS

Convertible tops and accessories require special care if you want to get the maximum usage and enjoyment from them. The following recommendations, if followed carefully, can extend the life of your top or accessory.

1. Hand wash using a mild non-detergent soap such as Ivory. Use a nonabrasive cloth or sponge. Rinse thoroughly.
2. **DO NOT** wash in direct sunlight and avoid automatic car washes.
3. When your doors are clean, we recommend using "303 Protectant" on both the vinyl and windows. This product contains a sunscreen that helps protect from the sun's damaging rays. Stay away from products containing alcohol as it will cause the fabric and windows to lose their elasticity, thus reducing the life of your top or accessory. If you are unable to locate "303 Protectant", **please call 1-800-223-4303 for a distributor near you.**
4. Direct sunlight and heat are the biggest enemies of the windows. Park in the shade whenever possible. If you must park in the sunlight, rotate the direction that you park every few days so all windows get even exposure.
5. **DO NOT** open or roll up windows at temperatures below 45 degrees F. This could cause them to crack or break.
6. **NEVER** use ice scrapers or snow brushes on vinyl windows.

