



# SPECIALTY TOP CO.

## INSTALLATION INSTRUCTIONS AMIGO PART #992-030

Thank you for purchasing Specialty's Convertible Top for your Amigo. It has been designed for great fit and long wear. Please read and follow, precisely, all installation instructions provided when installing top. Failure to do so may result in a poor fitting top and could place occupants in a potentially hazardous situation.

### TOOLS REQUIRED:

#2 PHILLIPS SCREWDRIVER  
STANDARD SCREWDRIVER

PLIERS  
ALCOHOL

### INSTALLATION TIPS

Before you begin installing this top, here are a few tips to make installation easier.

*This top should be installed where the temperature is above 72 degrees Fahrenheit. Below this temperature, the top may contract making it difficult to install.*

*It is normal for a top to contract and wrinkle when stored in the shipping carton. The top will relax and wrinkles will disappear within a few days of installation as fabric adjusts to shape of mounting hardware.*

### INSTALLATION PROCEDURES:

**1. Snap Stud Installation.** You will need to remove the two screws holding down the rubber seal immediately to the left and to the right of the tailgate. Replace these screws with #6-32 x 3/4 machine screw (Item 1) through snap stud (Item 2), 1/4" flat washer (Item 3), rubber seal and body. Secure with #6-32 hex nut (Item 4). See figure 1.

**2. Top Installation.** Clean surfaces for self adhesive hook with a 50% water and alcohol solution as indicated in figure 2. Attach self adhesive hook to vehicle. Snap center snap #1 on top center of vehicle. Pull top to the side and secure snap #2 to stud. Tuck seal into place and secure snap between #1 and #2 to studs on vehicle. Secure snaps #3

and #4 to studs on vehicle. Tuck seal into place and secure snap to vehicle between snaps #3 and #4. Secure Snaps #5 and #6 to studs on vehicle. Tuck seal into place and secure snap to vehicle between snaps #5 and #6. Press loop (sewn in top) to hook installed on vehicle. Repeat for the other side. When removing these snaps it is necessary to **first pull down** on the snap and then lift up. Snap sewn in bow flap to rear support bow. Wrap hook and loop flaps around center bow and press together. Pull rear curtain into position and secure with turn fasteners on vehicle. See figure 2.

**Rolling Up Side Panels.** It is possible to roll up your side panels or rear curtain to provide more ventilation in your vehicle. Prior to rolling side panels or rear curtain you must first make sure that windows are clean. If not properly cleaned dirt will scratch them reducing top life. It is also recommended to place a soft cloth between the glass and the retaining straps to prevent marring of the glass. To clean windows, wash them with a mild non-detergent soap and water. To roll up side panel, unzip rear curtain zippers, unsnap side panels, fold rear of side panel forward and roll up side panels. Secure with retaining straps on top. See figure 3. To roll up rear curtain follow the same procedure. You may roll up both side panels and rear curtain if you wish.

**Note:** On some early models there are turn fasteners all the way across the tailgate. If this is the case on your vehicle, you will need to remove one from each end of the tailgate and install a snap stud included in the small parts kit. Place screw through the snap stud, the tailgate and secure with hex nut.

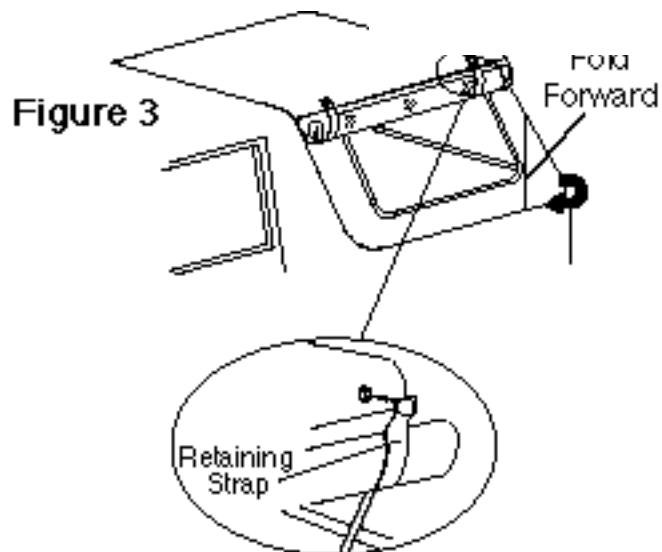
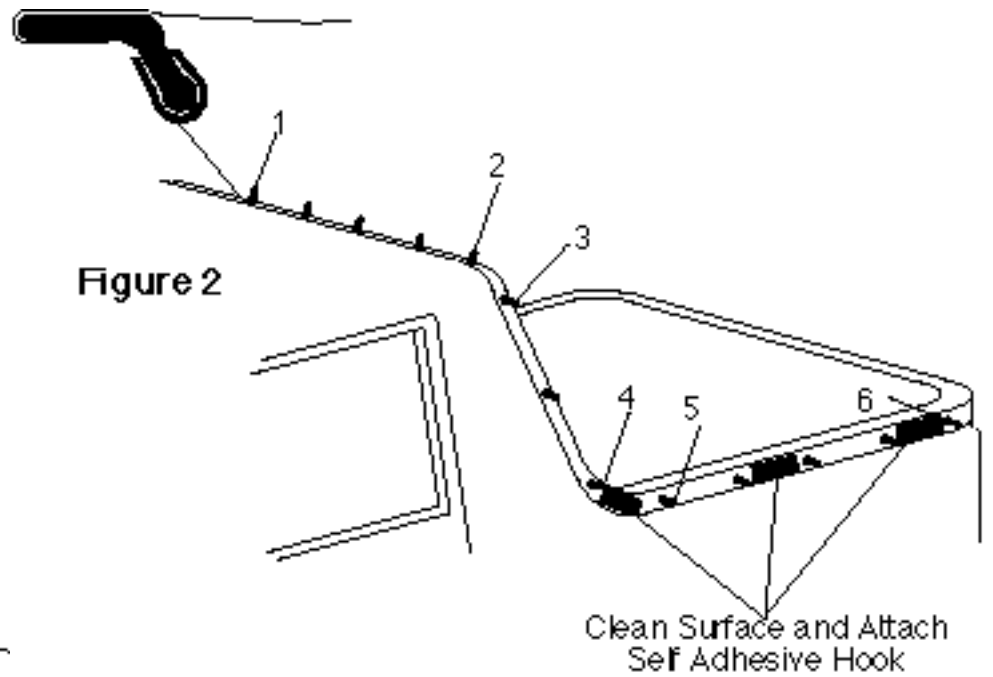
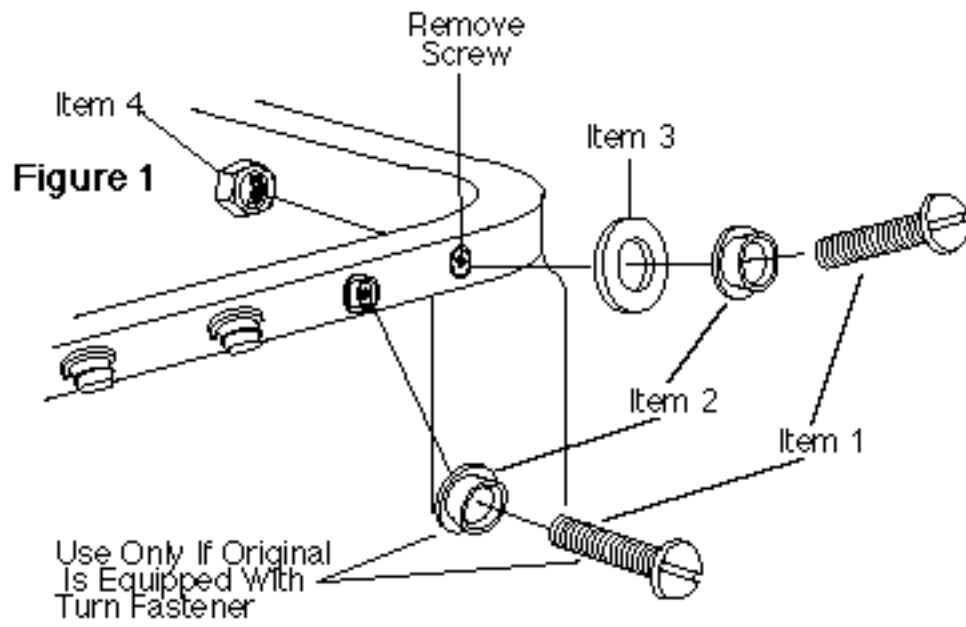

## CARE INSTRUCTIONS

Convertible tops and accessories require special care if you want to get the maximum usage and enjoyment from them. The following recommendations, if followed carefully, can extend the life of your top or accessory.

1. Hand wash using a mild non-detergent soap such as Ivory. Use a nonabrasive cloth or sponge. Rinse thoroughly.
2. **DO NOT** wash in direct sunlight and avoid automatic car washes.
3. When your top is clean, we recommend using "303 Protectant" on both the vinyl top and windows. This product contains a sunscreen that helps protect from the sun's damaging rays. Stay away from products containing alcohol as it will cause the fabric and windows to lose their elasticity, thus reducing the life of your top or accessory. If you are unable to locate "303 Protectant", please call 1-800-223-4303 for a distributor near you.
4. Direct sunlight and heat are the biggest enemies of the windows. Park in the shade whenever possible. If you must park in the sunlight, rotate the direction that you park every few days so all windows get even exposure.
5. Our tops are designed so that you may roll up and/or store the rear curtain and side curtains. To prevent scratching of the windows, be sure that windows are completely clean and free of dust particles. Even a little dirt will badly scratch the windows. You may want to use a soft cloth when rolling up or storing your windows. Heat may build up on rolled up windows, so be sure to unroll them frequently. If you roll up the windows at the beginning of summer and leave them, they may be ruined by fall.
6. **DO NOT** open or roll up windows at temperatures below 45 degrees F. This could cause them to crack or break.
7. **NEVER** use ice scrapers or snow brushes on vinyl windows.

## WARRANTY INFORMATION:

Specialty Top Co. manufacturing warrants to the original purchaser of any product it manufactures, that the product will be free of defects in material or workmanship for a period of 90 days from date of purchase. Such obligations under this warranty shall be limited to the **repair or replacement**, at Specialty's discretion, of any assembly or parts which upon examination by Specialty Top Co. proves to be defective. All defective items must be returned with proof of purchase to Specialty Top Co. Manufacturing, 200 East 64th Avenue, Denver, Colorado 80221, freight prepaid. This warranty does not cover damage resulting from abuse, misuse, alteration, accident or damage in transit. Specialty's obligations under this warranty are limited to the aforementioned repair or replacement of warranty defects for which the return authorization has been received during the warranty period, and **SPECIALTY TOP CO. SHALL NOT BE LIABLE FOR ANY INCIDENTAL OR CONSEQUENTIAL DAMAGES ARISING FROM BREACH OF THIS OR ANY IMPLIED WARRANTY.**

Some states do not allow the exclusion or limitation of incidental or consequential damages, so the above limitation or exclusion may not apply to you. This warranty gives you specific legal rights, and you may also have other rights which may vary from state to state.

If you need assistance or further information, you may contact Specialty Top Co. at 1-866-487-9944 between the hours of 8:00 AM and 5:00 PM, Monday through Friday, Mountain Standard Time.