



SPECIALTY TOP CO.

INSTALLATION INSTRUCTIONS 76-91 BLAZER FAST TRAC PART #553-310

Thank you for purchasing Specialty's Convertible Top for your Blazer. It has been designed for great fit and long wear. Please read and follow, precisely, all installation instructions provided when installing top. Failure to do so may result in a poor fitting top and could place occupants in a potentially hazardous situation.

TOOLS REQUIRED:

3/8" WRENCH	7/16" WRENCH
1/8" DRILL BIT	3/32" DRILL BIT
3/16" DRILL BIT	1/2" DRILL BIT
ELECTRIC DRILL	#2 PHILLIPS SCREWDRIVER
8' TAPE MEASURE	

INSTALLATION TIPS

Before you begin installing this top, here are a few tips to make installation easier.

This top should be installed where the temperature is above 72 degrees Fahrenheit. Below this temperature, the top may contract making it difficult to install.

It is normal for a top to contract and wrinkle when stored in the shipping carton. The top will relax and wrinkles will disappear within a few days of installation as fabric adjusts to shape of mounting hardware.

INSTALLATION PROCEDURES:

On page 4 of this instruction manual there is an assembly drawing. Please refer to it for identification of parts and assembly assistance. Also refer to page 6 to assure that all parts are included in your kit.

Step 1. Body Aluminum. Mount rear body aluminum (Item 1) to the top edge of body. Place 5/16-18 x 3/4 hex bolts (Item 2) through 5/16" flat washers (Item 3), body aluminum and into existing holes in top of body. Butt front body aluminum (Item 4) to rear body aluminum and attach to the body using the same procedure as above. Front and rear body aluminum should be in line with each other from front to rear. See figure 1.

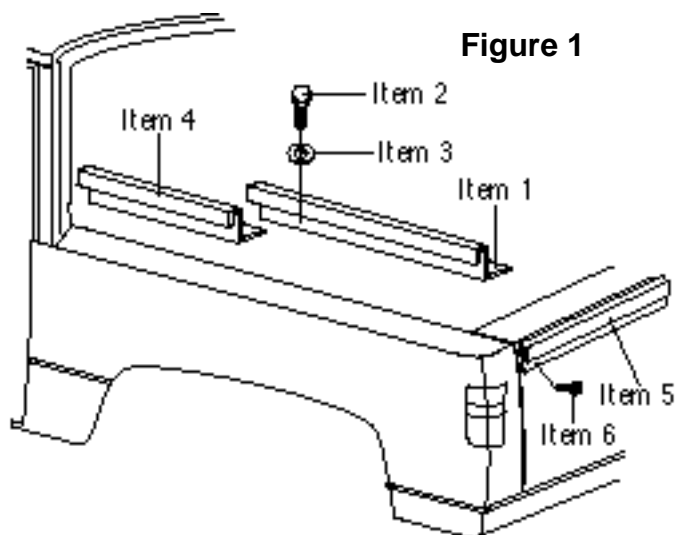

Figure 1

Step 2. Tailgate Aluminum. Mount tailgate aluminum (Item 5) to tailgate just above rolled edge (approximately 1/4" down from top edge of tailgate). Using tailgate aluminum as a template, mark and drill 1/8" holes. Secure to tailgate with #10 x 1/2" sheet metal screws (Item 6). Butt right side of tailgate aluminum to left side. Mark and drill holes and secure using same procedure as above. See figure 1.

Step 3. Cab Aluminum. Measure up 1 1/4" from top of body at rear of cab on the driver's side. This will be the starting point for mounting the cab aluminum. Place end of left cab aluminum (Item 7) at this point. Mark and drill 1/8" holes using cab aluminum as a template starting at the bottom and working your way to top center of cab. Install one #10 x 1/2" sheet metal screw (Item 6) at a time, keeping front of cab aluminum as far forward as possible and bending where needed to follow contour at rear of cab. See figure 2. Butt end of right cab aluminum to cab aluminum just installed and secure to cab using same procedure as above. See figure 2-A

Step 4. Bow Mount. Measure 34 1/2" from rear of cab and mark for position of bow mount (Item 8). Place bow mount in notch in body aluminum at this point. Using bow mount as a template, mark and drill two 5/32" holes, one at the front outside of bracket and one at the rear outside of bracket. Secure with #14 x 1/2" hex head sheet metal screws (Item 9). Repeat for the other side. See figure 3.

Step 5. Bows. Secure bow release bracket (Item 10) to bow mount by placing 1/4-20 x 1 1/2" hex head bolt (Item 11) through one side of bow mount, the bow release bracket and the other side of bow mount. Secure with 1/4-20 lock nut (Item 12). These items must pivot so do not over tighten. Repeat for other side. Place bow sleeves (Item 13) over rear bow halves (Item 14). Slide rear bow halves together. Mount rear bow into center set of holes in bow release bracket by placing 1/4-20 x 1 1/2" hex head bolt (Item 11) through one side of release bracket, rear bow and then through the other side of release bracket. Secure with 1/4-20 lock nut (Item 12). Again these items must pivot so do not over tighten. Repeat for the other side. Slide bow sleeves (Item 13) over front bow halves (Item 15). Place front bow into front of bow mount so that the large holes in bow are facing towards the front of vehicle. Place 1/4-20 x 1 1/2" hex head bolt through one side of bow mount, front bow and through other side of bow mount. Secure with 1/4-20 lock nut. Once again these items must pivot so do not over tighten. Repeat for the other side. See figure 3.

Figure 2

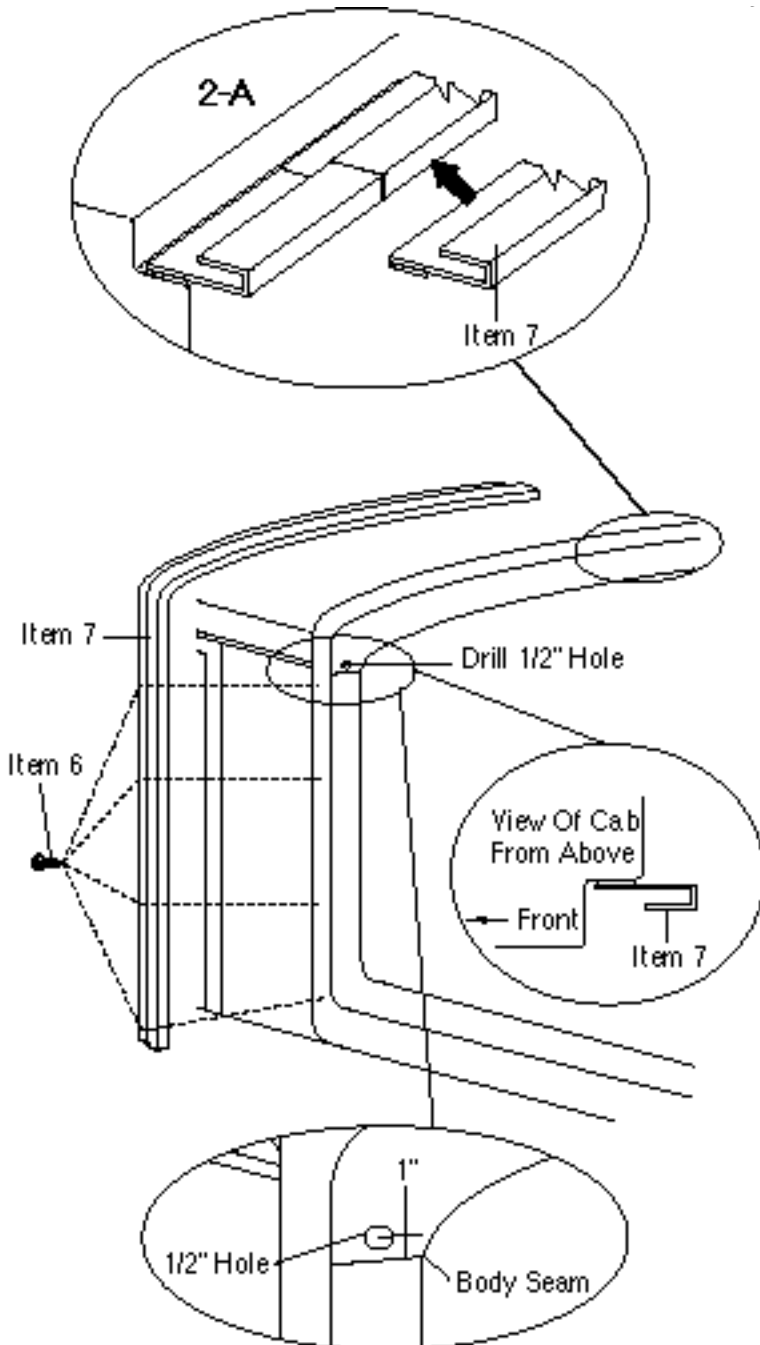
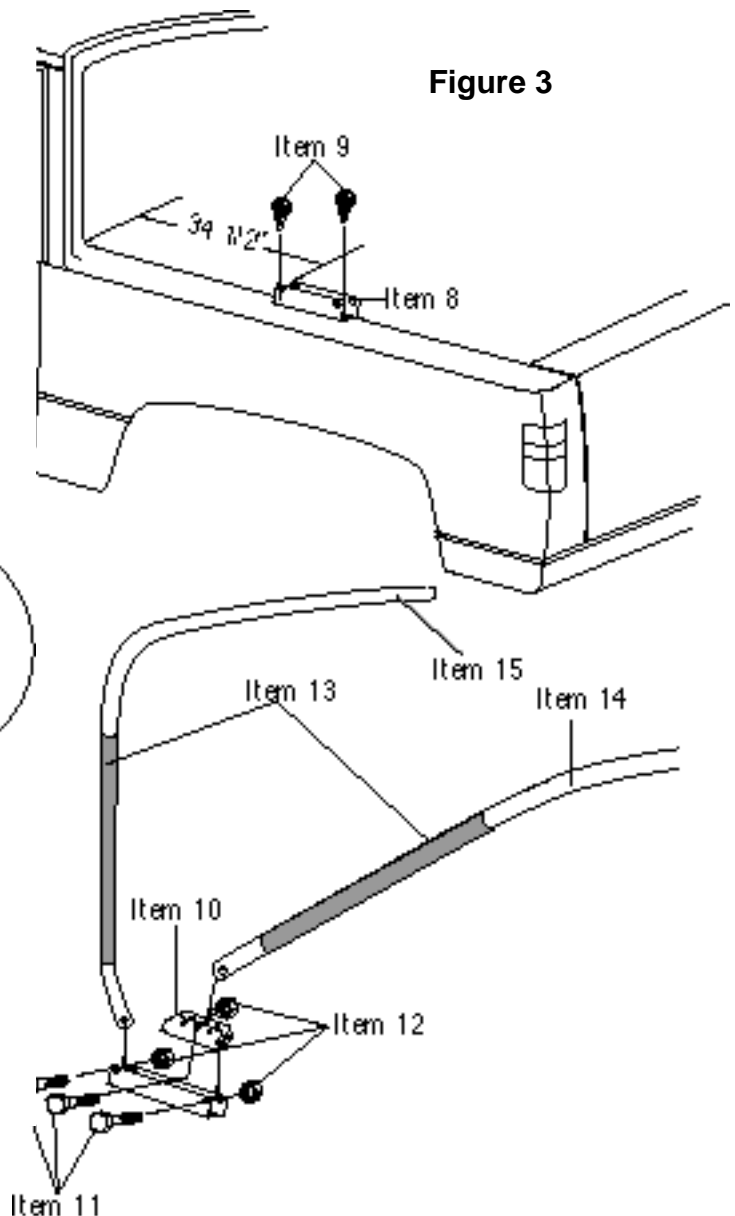
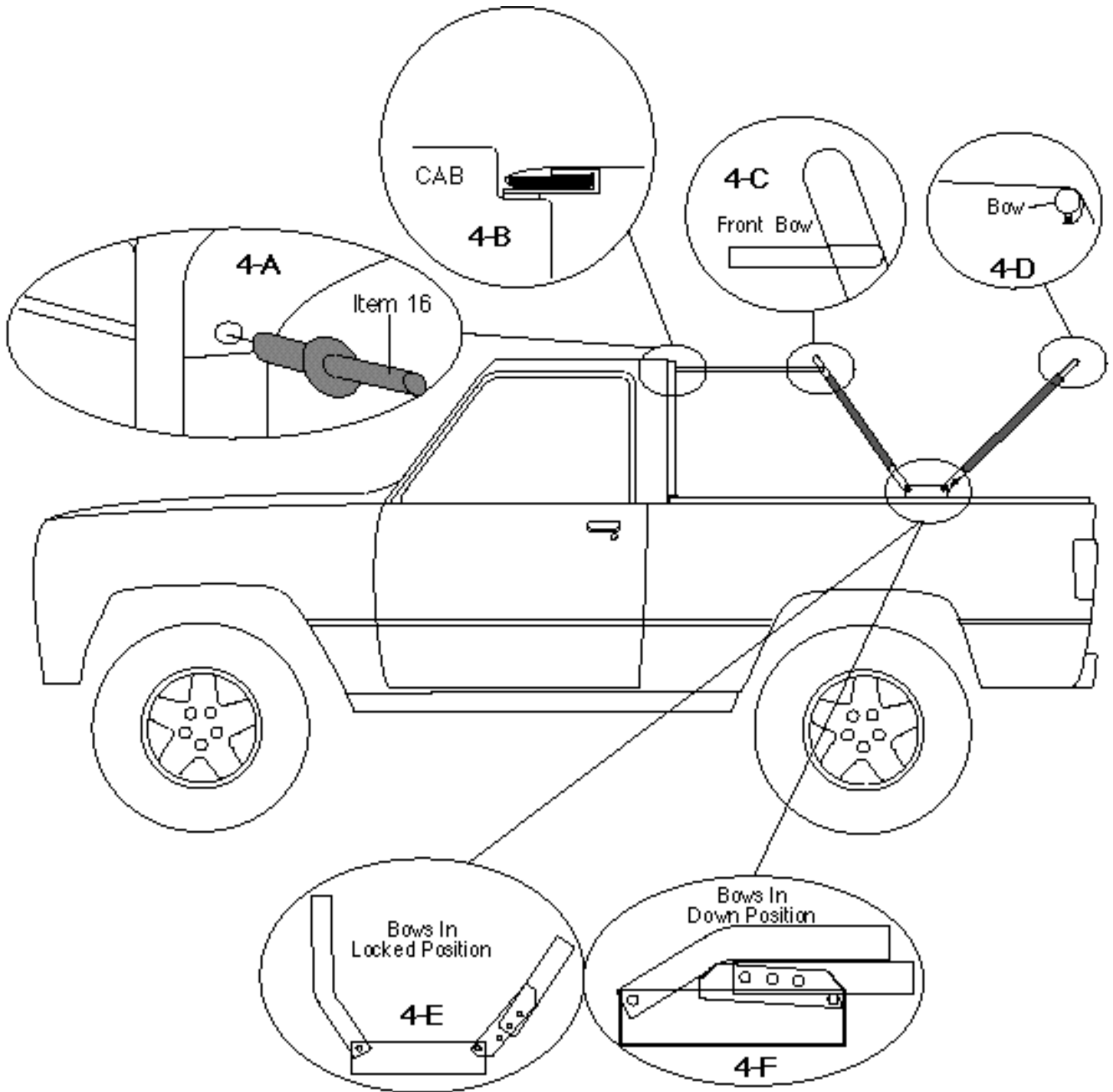

Figure 3



Step 6. Horizontal Rods. Mark and drill a 1/2" hole 1" above body seam at upper rear corners of cab centered from side to side. Pull front bow forward and insert small end of horizontal rod (Item 16) into hole in front bow. Insert the other end into 1/2" hole just drilled. See figure 4-A and 4-C.



Installing Vinyl Top. Place convertible top vinyl side down on top of cab. Insert sewn in plastic at front of top, into slot in cab aluminum. See figure 4-B. Pull top over support bows. Snap front and rear bow flaps to their respective bows. See figure 4-D. With the rear bow in the unlocked position (see figure 4-F) clip K-locks to body aluminum. Make sure that the closed end of the last K-lock fully captivates the end of the body aluminum. See figure 5A. Slip sewn in plastic into slot in tailgate aluminum. See figure 5-B. Zip side panels closed. Slip sewn in plastic at front of side panels into slot in cab aluminum. Zip rear curtain closed and slip sewn in plastic at bottom of rear curtain into slot in tailgate aluminum. Partially unzip each side of the rear curtain. Reach in and pull the rear bow into the locked position (see figure 4-E) making sure that the K-locks and sewn in plastic remain in cab aluminum, tailgate aluminum and body aluminum. Press hook and loop together at rear of side panels.

Figure 5

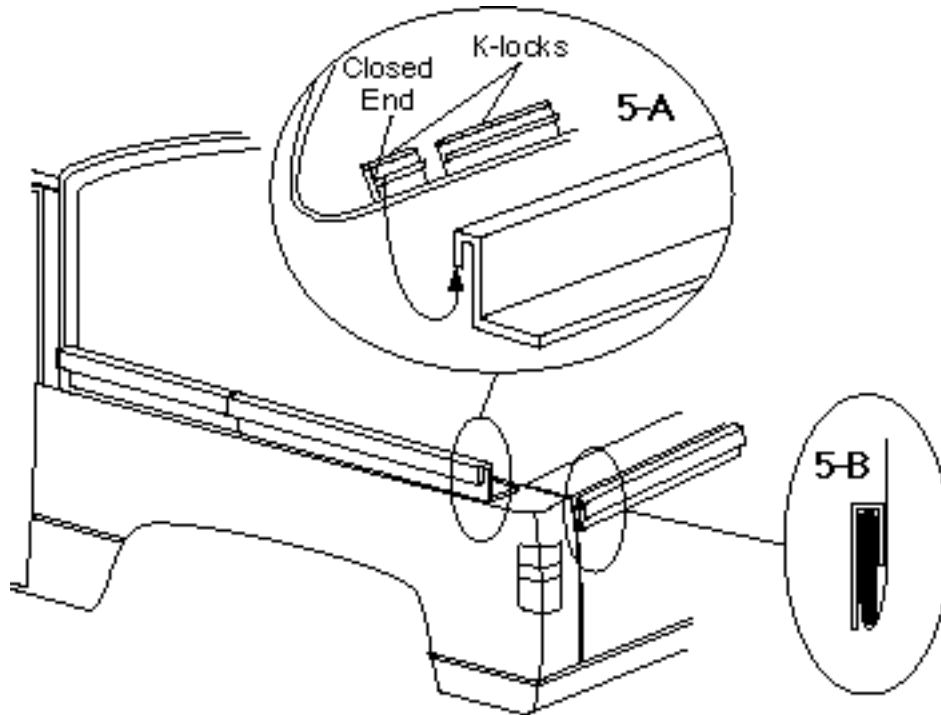

WARRANTY INFORMATION:

Specialty Top Co. manufacturing warrants to the original purchaser of any product it manufactures, that the product will be free of defects in material or workmanship for a period of 90 days from date of purchase. Such obligations under this warranty shall be limited to the **repair or replacement**, at Specialty's discretion, of any assembly or parts which upon examination by Specialty Top Co. proves to be defective. All defective items must be returned with proof of purchase to Specialty Top Co. Manufacturing, 200 East 64th Avenue, Denver, Colorado 80221, freight prepaid. This warranty does not cover damage resulting from abuse, misuse, alteration, accident or damage in transit. Specialty's obligations under this warranty are limited to the aforementioned repair or replacement of warranty defects for which the return authorization has been received during the warranty period, and **SPECIALTY TOP CO. SHALL NOT BE LIABLE FOR ANY INCIDENTAL OR CONSEQUENTIAL DAMAGES ARISING FROM BREACH OF THIS OR ANY IMPLIED WARRANTY.**

Some states do not allow the exclusion or limitation of incidental or consequential damages, so the above limitation or exclusion may not apply to you. This warranty gives you specific legal rights, and you may also have other rights which may vary from state to state.

If you need assistance or further information, you may contact Specialty Top Co. at 1-866-487-9944 between the hours of 8:00 AM and 5:00 PM, Monday through Friday, Mountain Standard Time.

PARTS IDENTIFICATION

Item 1
Rear Body Aluminum
1 Left Shown, 1 Right

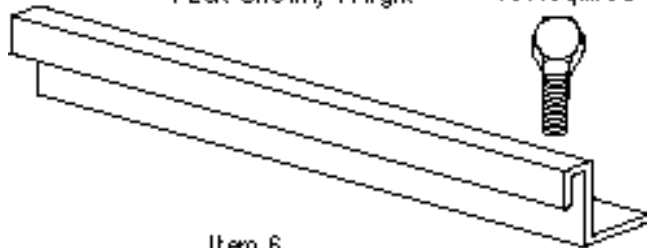

Item 2
5/16-18 Hex Bolt
10 Required



Item 3
5/16" Flat Washer
10 Required



Item 4
Front Body Aluminum
1 Left Shown, 1 Right

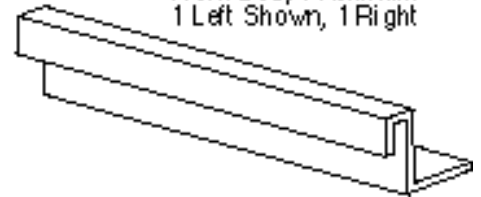

Item 6
Tailgate Aluminum
1 Left Shown, 1 Right

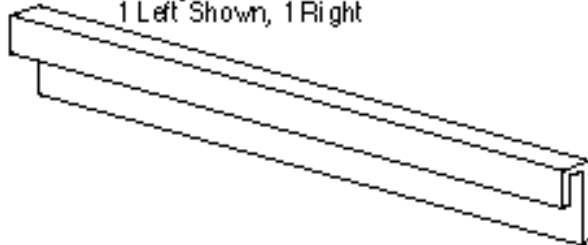

Item 6
#10 x 1/2" Sheet Metal Screw
23 Required



Item 7
Cab Aluminum
1 Left Shown, 1 Right

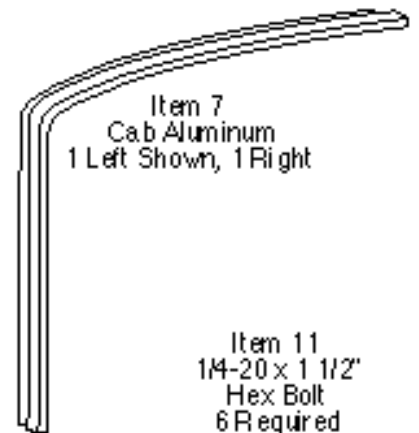

Item 8
Bow Mount Bracket
2 Required



Item 9
#14 x 1/2" Sheet Metal Screw
4 Required



Item 10
Bow Release Bracket
2 Required



Item 11
1/4-20 x 1 1/2" Hex Bolt
6 Required



Item 14
Rear Bow
1 Left Shown - 1 Right



Item 15
Front Bow
1 Left Shown - 1 Right

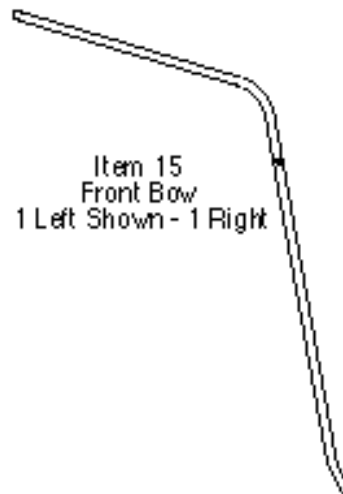

Item 12
1/4-20 Lock Nut
6 Required



Item 13
Bow Sleeve
4 Required

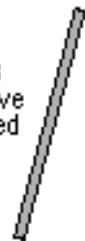

Item 16
Horizontal Rod
2 Required



Storing Side Panels And Rear curtain. Before storing panels, clean windows with a mild non-detergent soap and water. If windows are not clean, dirt will scratch them reducing top life. **It is also advisable to place a soft cloth on your windows prior to storing them to prevent scratching and marring of window glass.** To store the side panels and rear curtain, you must unzip rear curtain and unlock the rear bow. Unfasten K-locks and plastic from body aluminum and tailgate aluminum. Lock the rear bow making sure that rear corner pieces of K-lock are in place and plastic is seated in the tailgate aluminum. Fold side panels at spacing between K-locks and store in the bag provided. Fold rear curtain and store in bag provided. Do not crease window glass or lay heavy objects on folded windows or damage may result.

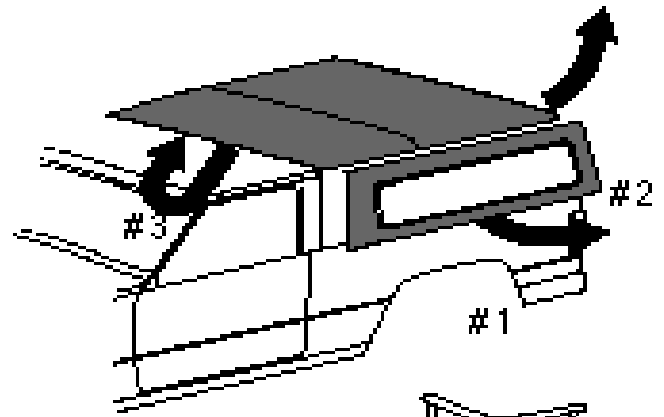

FOLDING INSTRUCTIONS

Step 1. Unlock rear bow. Remove side panels and rear curtain and store in bags provided. Fold rear corners onto top of convertible top.

#4

Step 2. Remove front of top from cab aluminum. Fold front of convertible top to the rear, over bows. Remove horizontal rods. Continue to fold bows to the rear of vehicle as top sags between bows. The bow should come to rest on top of tailgate. There is a convertible boot available to protect your top while in the down position. Contact your dealer for pricing and availability.

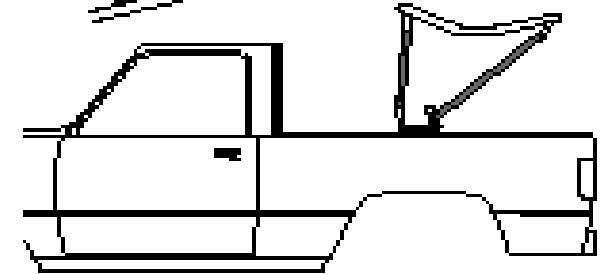

#5

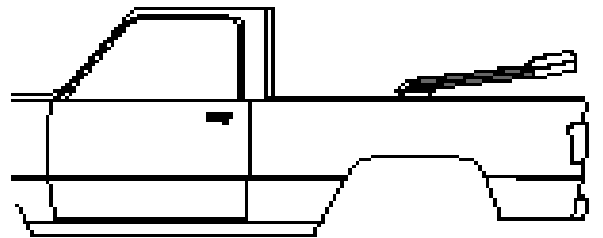

CARE INSTRUCTIONS

Convertible tops and accessories require special care if you want to get the maximum usage and enjoyment from them. The following recommendations, if followed carefully, can extend the life of your top or accessory.

1. Hand wash using a mild non-detergent soap such as Ivory. Use a nonabrasive cloth or sponge. Rinse thoroughly.
2. **DO NOT** wash in direct sunlight and avoid automatic car washes.
3. When your top is clean, we recommend using "303 Protectant" on both the vinyl top and windows. This product contains a sunscreen that helps protect from the sun's damaging rays. Stay away from products containing alcohol as it will cause the fabric and windows to lose their elasticity, thus reducing the life of your top or accessory. If you are unable to locate "303 Protectant", please call 1-800-223-4303 for a distributor near you.
4. Direct sunlight and heat are the biggest enemies of the windows. Park in the shade whenever possible. If you must park in the sunlight, rotate the direction that you park every few days so all windows get even exposure.
5. Our tops are designed so that you may roll up and/or store the rear curtain and side curtains. To prevent scratching of the windows, be sure that windows are completely clean and free of dust particles. Even a little dirt will badly scratch the windows. You may want to use a soft cloth when rolling up or storing your windows. Heat may build up on rolled up windows, so be sure to unroll them frequently. If you roll up the windows at the beginning of summer and leave them, they may be ruined by fall.
6. **DO NOT** open or roll up windows at temperatures below 45 degrees F. This could cause them to crack or break.
7. **NEVER** use ice scrapers or snow brushes on vinyl windows.