



SPECIALTY TOP CO.

INSTALLATION INSTRUCTIONS 1973-1975 BLAZER/JIMMY FAST TRAC PART #552-310

Thank you for purchasing Specialty's Convertible Top for your vehicle. It has been designed for great fit and long wear. Please read and follow, precisely, all installation instructions provided when installing top. Failure to do so may result in a poor fitting top and could place occupants in a potentially hazardous situation.

TOOLS REQUIRED:

3/8" WRENCH	7/16" WRENCH
1/2" WRENCH	#2 PHILLIPS SCREWDRIVER
1/8" DRILL BIT	5/32" DRILL BIT
3/8" DRILL BIT	ELECTRIC DRILL
8' TAPE MEASURE	RUBBING ALCOHOL

INSTALLATION PROCEDURES:

On page 3 of this instruction manual there is an assembly drawing. Please refer to it for identification of parts and assembly assistance. Also refer to page 5 to assure that all parts are included in your kit.

INSTALLATION TIPS

Before you begin installing this top, here are a few tips to make installation easier.

This top should be installed where the temperature is above 72 degrees Fahrenheit. Below this temperature, the top may contract making it difficult to install.

It is normal for a top to contract and wrinkle when stored in the shipping carton. The top will relax and wrinkles will disappear within a few days of installation as fabric adjusts to shape of mounting hardware.

Step 1. Body Aluminum. Mount rear body aluminum (Item 1) to the top edge of body. Place 5/16-18 x 3/4 hex bolts (Item 2) through 5/16" flat washers (Item 3), body aluminum and into existing holes in top of body. Butt front body aluminum (Item 4) to rear body aluminum and attach to the body using the same procedure as above. Front and rear body aluminum should be in line with each other from front to rear. See figure 1.

Step 2. Tailgate Aluminum. Mount tailgate aluminum (Item 5) to tailgate just below rolled edge (approximately 1/4" down from top edge of tailgate). Using tailgate aluminum as a template, mark and drill 1/8" holes. Secure to tailgate with #10 x 1/2" sheet metal screws (Item 6). Butt right side of tailgate aluminum to left side. Mark and drill as above. See

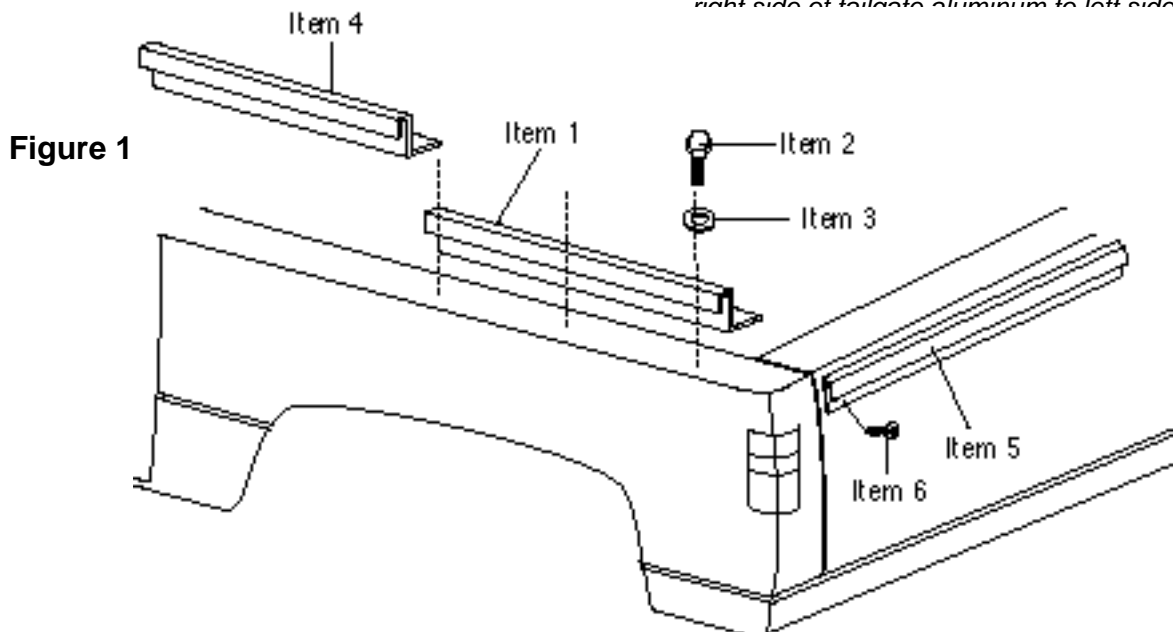

Step 3. Windshield Aluminum. Place windshield aluminum (Item 7) on front of windshield frame centered from side to side. The bottom of windshield aluminum should be to the bottom of channel in windshield frame. Mark and drill 1/8" holes using windshield aluminum as a template starting at the center. Install one #10 x 1/2" sheet metal screw (Item 6) at a time starting at the center and working your way to each side of windshield frame. See figure 4-A.

Step 4. Bow Mount. Using rear body aluminum as a template mark and drill two 5/32" holes. Place rear bow mount (Item 8) over holes just drilled. Secure to body with #14 x 1/2" sheet metal screws (Item 9). Using front body aluminum as a template mark and drill two 5/32" holes. Place front bow mount (Item 10) over holes just drilled. Secure to body with #14 x 1/2" sheet metal screws (Item 9). Repeat for the other side. See figure 2.

Step 5. Bows. Secure bow release bracket (Item 12) to bow mount by placing 1/4-20 x 1 1/2" hex head bolt (Item 11) through one side of bow mount, the bow release bracket and the other side of bow mount. Secure with 1/4-20 lock nut (Item 13). These items must pivot so do not over tighten. Repeat for other side. Place bow sleeves (Item 14) over rear bow halves (Item 15). Slide rear bow halves together. Mount rear bow into center set of holes in bow release bracket by placing 1/4-20 x 1 1/2" hex head bolt (Item 11) through one side of release bracket, rear bow, and then through the other side of release bracket. Secure with 1/4-20 lock nut (Item 13). Again these items must pivot so do not over tighten. Repeat for the other side. Slide bow sleeves (Item 14) over center bow halves (Item 16). Slide center bow halves together. Place center bow into forward edge of rear bow mount so that the large holes in bow are facing towards the front of vehicle. Place 1/4-20 x 1 1/2" hex head bolt through one side of bow mount, front bow and through other side of bow mount. Secure with 1/4-20 lock nut. Once again these items must pivot so do not over tighten. Repeat for the other side. See figure 3. Slide bow sleeves (Item 14) over front bow halves (Item 17). Slide front bow halves together. Place 1/4-20 x 1 1/2" hex head bolt through one side of bow mount, front bow and

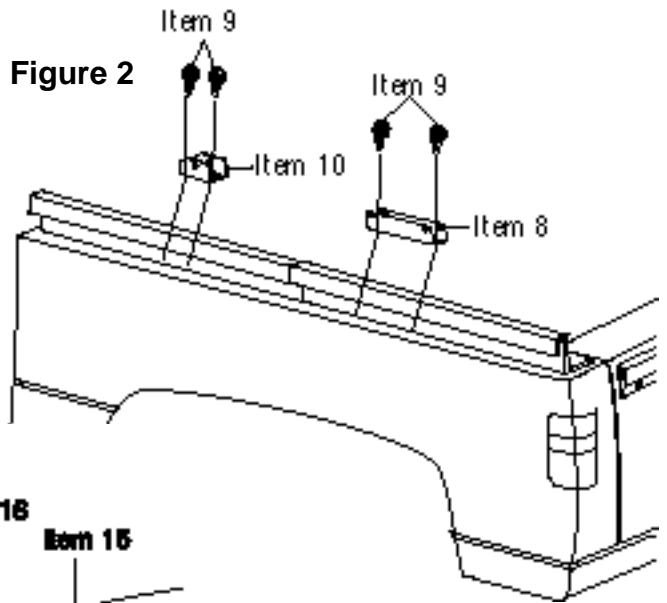

Figure 2

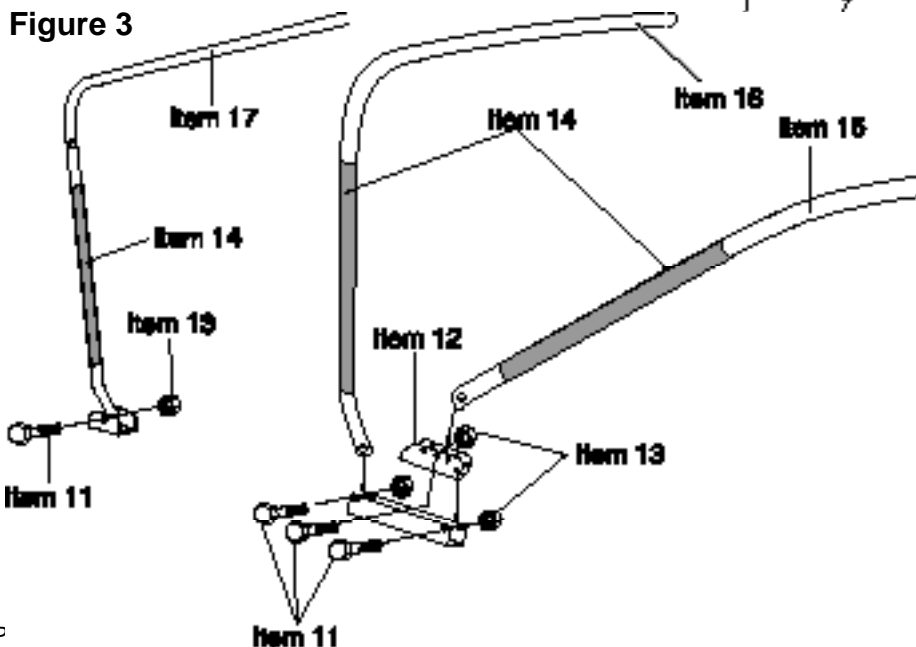
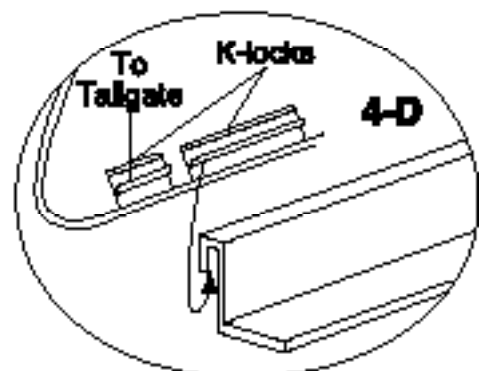
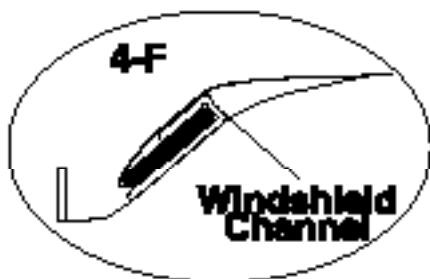
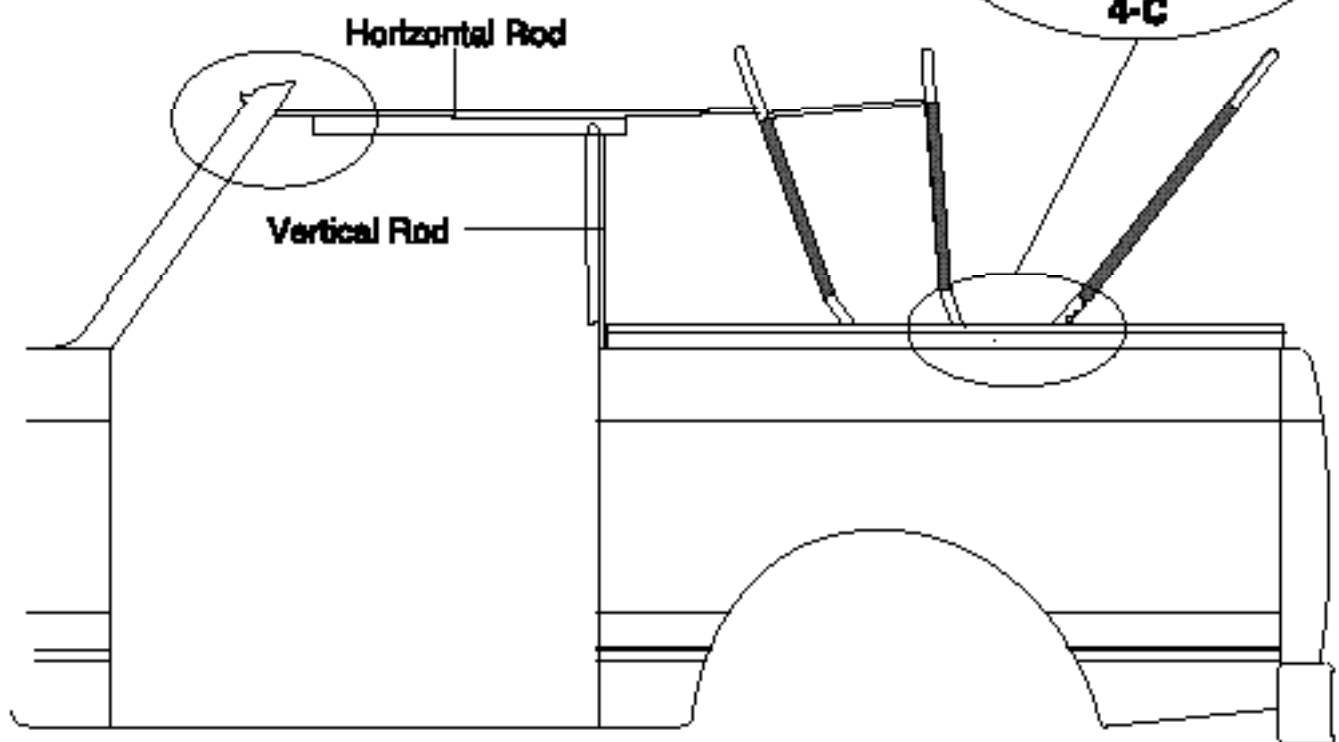
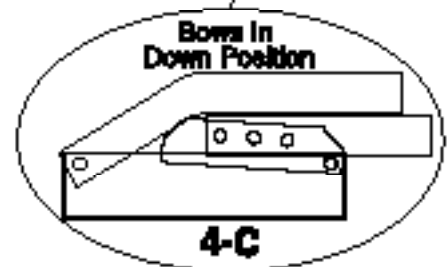
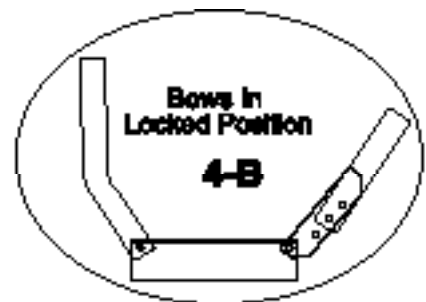
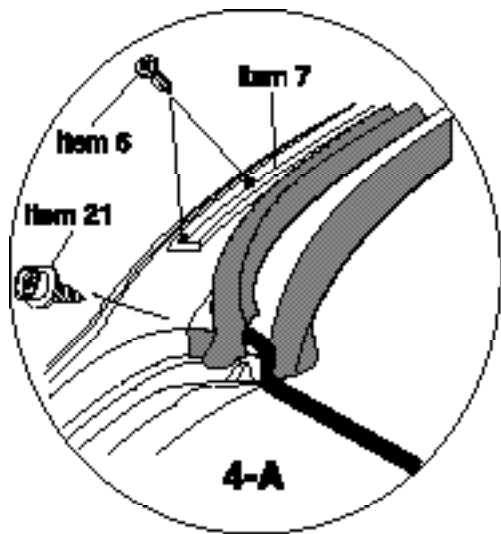

Figure 3



Step 6. Horizontal Rods. Pull the front bow forward and place rear of the horizontal rod (Item 18) into large hole in the front bow. The right horizontal rod is marked with a white dot at the front of the rod. With the door closed and the window rolled up, find the position of horizontal rod hole at windshield frame. With the horizontal rod parallel with the top of the door glass mark hole location at windshield frame. Drill 3/8" hole. The rubber seal at corners of windshield frame may require trimming to drill holes for horizontal rods. See figure 4.

Step 7. Vertical Rods. Place vertical rods (item 19) at rear of door opening next to window glass with the door closed. The right vertical rod is marked with a white dot at the bottom of the rod. With the weather stripping on the rod parallel with and touching the glass mark and drill a 3/8" hole in the top of the body at the point where the rod meets the top of body. This position is approximately 1 1/2" from the inside edge of the body and near the forward edge of the door opening. This measurement may vary due to inconsistency of these older vehicles. Remove wing nut and washer from horizontal rod. Place vertical rod over stud on horizontal rod and secure with washer and wing nut. Repeat for the other side. Pull center bow forward and place 23" spacer rod (Item 20) into front hole of center bow. Place the other end of the rod into rear hole of front bow. Repeat for the other side.

Installing Vinyl Top. Place front of vinyl top into windshield channel. See figure 4-F. Flip top over windshield frame and support bows. Snap outside snaps on bow flaps to outside snaps on support bows. Snap remaining snaps to bows. Center vinyl top from side to side on windshield frame.

Clip K-Locks to body aluminum and tailgate retainerr. See figure 4-D. Slip sewn in plastic at rear of top into tailgate aluminum.

Place loop at rear of side panel onto hook at rear section of vinyl top. Starting at the door opening zip side panel to top. Repeat for the other side. Clip K-locks to body aluminum. Place sewn in plastic at front of side panel into channel in vertical rod. Place sewn in plastic at top front of side panel into channel on horizontal rod. See figure 4-F. Place sewn in plastic at door opening of vinyl top into channel of horizontal rod.

Starting at lower drivers side of tailgate opening zip in rear curtain. Center rear curtain from side to side. Place sewn in plastic at bottom of rear curtain into tailgate aluminum. See figure 4-E. Unzip each side of rear curtain. Reach into vehicle and pull rear bows into locked position. See figure 4-B. Close zipper at each side of rear curtain.

Two snaps will need to be installed at each side of windshield aluminum. See figure 4-A. Mark for these positions by pulling vinyl top to the side. Drill 1/8" hole and install 3/8" sheet metal screw studs (Item 21). Snap top to studs. Repeat for the other side.

Pull at front corner of vinyl top forward and down to outside of windshield frame. Mark and drill 1/8" hole and install 3/8" sheet metal screw stud at this point. Snap top to stud. This pulls the drip rail taught to shed water away from door opening and side panels.

FOLDING INSTRUCTIONS

Step 1. Unlock rear bow and unfasten K-locks. Remove side panels and rear curtain and store in bag provided.

Step 2. Unfasten top from windshield frame and fold front of top towards the rear of the vehicle. Unfasten snaps from front bow flap and fold top to the rear of vehicle. Continue to fold top to the rear of vehicle as center and rear bows come to rest on tailgate.

Step 3. Clip K-locks (at rear corners of vehicle) to body aluminum and tailgate aluminum. Lock rear bow into position to keep tension on the convertible top. See figure 4-D.

PARTS IDENTIFICATION

Item 1
Rear Body Aluminum
1 Left, 1 Right



Item 2
5/16-18 x 3/4" Hex Bolt
10 Required



Item 3
6/16" Flat Washer
10 Required



Item 4
Front Body Aluminum
1 Left, 1 Right

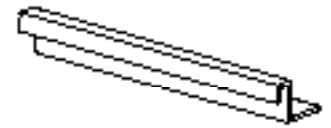

Item 5
Tailgate Aluminum
1 Left, 1 Right



Item 6
#10 x 1/2"
Sheet Metal Screw
14 Required



Item 7
Windshield Aluminum
1 Required



Item 8
Rear Bow Mount
2 Required



Item 9
#14 x 1/2" Sheet
Metal Screw
8 Required



Item 10
Front Bow Mount
2 Required



Item 11
1/4-20 x 1 1/2"
Hex Bolt
6 Required



Item 12
Bow Release Bracket
2 Required



Item 13
1/4-20 Lock Nut
6 Required

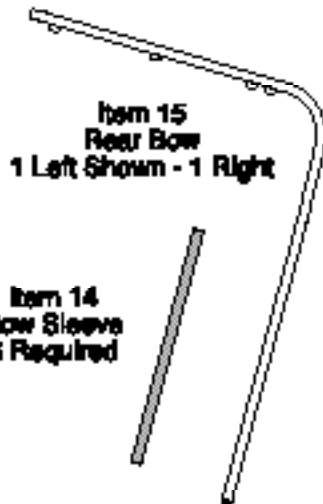

Item 15
Rear Bow
1 Left Shown - 1 Right

Item 14
Bow Sleeve
6 Required



Item 16
Center Bow
1 Left Shown - 1 Right

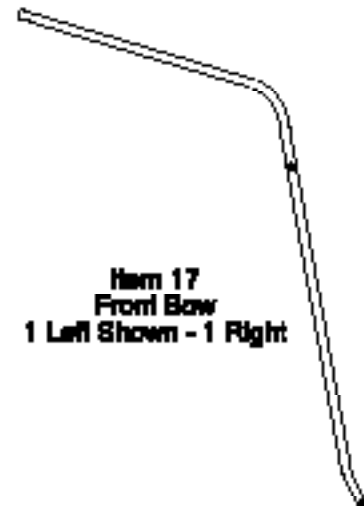

Item 17
Front Bow
1 Left Shown - 1 Right

Item 18
Horizontal Rod
1 Left Shown - 1 Right



Item 19
Vertical Rod
1 Left Shown - 1 Right



Item 20
25" Spacer Rod
2 Required



Item 21
Sheet Metal
Screw Stud
4 Required



CARE INSTRUCTIONS

Convertible tops and accessories require special care if you want to get the maximum usage and enjoyment from them. The following recommendations, if followed carefully, can extend the life of your top or accessory.

- 1. Hand wash using a mild non-detergent soap such as Ivory. Use a nonabrasive cloth or sponge. Rinse thoroughly.*
- 2. **DO NOT** wash in direct sunlight and avoid automatic car washes.*
- 3. When your top is clean, we recommend using "303 Protectant" on both the vinyl top and windows. This product contains a sunscreen that helps protect from the sun's damaging rays. Stay away from products containing alcohol as it will cause the fabric and windows to lose their elasticity, thus reducing the life of your top or accessory. If you are unable to locate "303 Protectant", please call 1-800-223-4303 for a distributor near you.*
- 4. Direct sunlight and heat are the biggest enemies of the windows. Park in the shade whenever possible. If you must park in the sunlight, rotate the direction that you park every few days so all windows get even exposure.*
- 5. Our tops are designed so that you may roll up and/or store the rear curtain and side curtains. To prevent scratching of the windows, be sure that windows are completely clean and free of dust particles. Even a little dirt will badly scratch the windows. You may want to use a soft cloth when rolling up or storing your windows. Heat may build up on rolled up windows, so be sure to unroll them frequently. If you roll up the windows at the beginning of summer and leave them, they may be ruined by fall.*
- 6. **DO NOT** open or roll up windows at temperatures below 45 degrees F. This could cause them to crack or break.*
- 7. **NEVER** use ice scrapers or snow brushes on vinyl windows.*

WARRANTY INFORMATION:

*Specialty Top Co. manufacturing warrants to the original purchaser of any product it manufactures, that the product will be free of defects in material or workmanship for a period of 90 days from date of purchase. Such obligations under this warranty shall be limited to the **repair or replacement**, at Specialty's discretion, of any assembly or parts which upon examination by Specialty Top Co. proves to be defective. All defective items must be returned with proof of purchase to Specialty Top Co. Manufacturing, 200 East 64th Avenue, Denver, Colorado 80221, freight prepaid. This warranty does not cover damage resulting from abuse, misuse, alteration, accident or damage in transit. Specialty's obligations under this warranty are limited to the aforementioned repair or replacement of warranty defects for which the return authorization has been received during the warranty period, and **SPECIALTY TOP CO. SHALL NOT BE LIABLE FOR ANY INCIDENTAL OR CONSEQUENTIAL DAMAGES ARISING FROM BREACH OF THIS OR ANY IMPLIED WARRANTY.***

Some states do not allow the exclusion or limitation of incidental or consequential damages, so the above limitation or exclusion may not apply to you. This warranty gives you specific legal rights, and you may also have other rights which may vary from state to state.

If you need assistance or further information, you may contact Specialty Top Co. at 1-866-487-9944 between the hours of 8:00 AM and 5:00 PM, Monday through Friday, Mountain Standard Time.