



SPECIALTY TOP CO.

INSTALLATION INSTRUCTIONS Scout II - Fast Trac PART #442-210

Thank you for purchasing Specialty's Convertible Top for your Scout vehicle. It has been designed for great fit and long wear. Please read and follow, precisely, all installation instructions provided when installing top. Failure to do so may result in a poor fitting top and could place occupants in a potentially hazardous situation.

TOOLS REQUIRED:

3/8" WRENCH
8' TAPE MEASURE
ELECTRIC DRILL
RUBBING ALCOHOL
7/16" WRENCH
#2 PHILLIPS SCREWDRIVER
DRILL BITS (1/8", 5/32", 3/8")

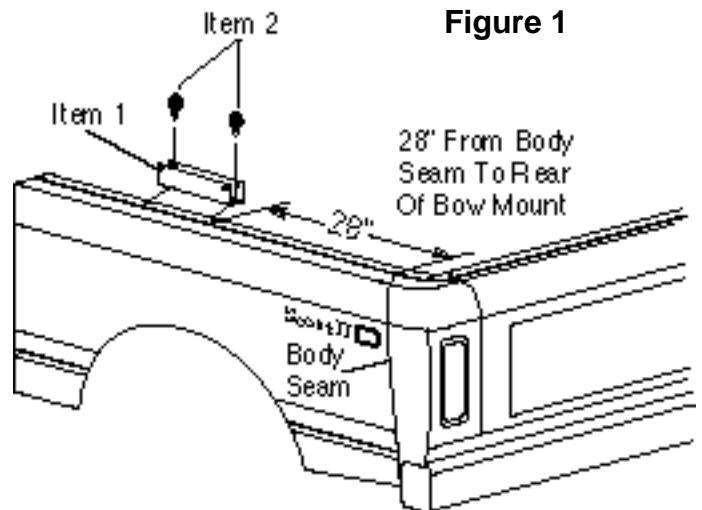

INSTALLATION TIPS

Before you begin installing this top, here are a few tips to make installation easier.

This top should be installed where the temperature is above 72 degrees Fahrenheit. Below this temperature, the top may contract making it difficult to install.

It is normal for a top to contract and wrinkle when stored in the shipping carton. The top will relax and wrinkles will disappear within a few days of installation as fabric adjusts to shape of mounting hardware.

INSTALLATION PROCEDURES:

On page 3 of this instruction manual there is an assembly drawing. Please refer to it for identification of parts and assembly assistance. Also refer to page 6 to assure that all parts are included in your kit.

Step 1. Bow Mount. Measure 28" from the body seam at corner and mark a line on raised level of the body. The rear of the bow mount (Item 1) will be positioned on this line. Using bow mount as a template, mark and drill 5/32" holes. Only one front and one rear hole of bow mount will be used. Secure bow mount to body with #14 x 1/2" sheet metal screws (Item 2). Repeat for the other side. See figure 1.

Step 2. Body Aluminum. Locate first piece of body aluminum (Item 3) just outside slight drop in body edge. The front of the body aluminum should be even with rear of door opening and parallel with outside edge of body. Using body aluminum as a template, mark and drill 1/8" holes. Secure to body with #10 x 1/2" sheet metal screw (Item 4). Butt another piece of body aluminum up to body aluminum just installed and secure to body. Repeat for the other side. See figure 2.

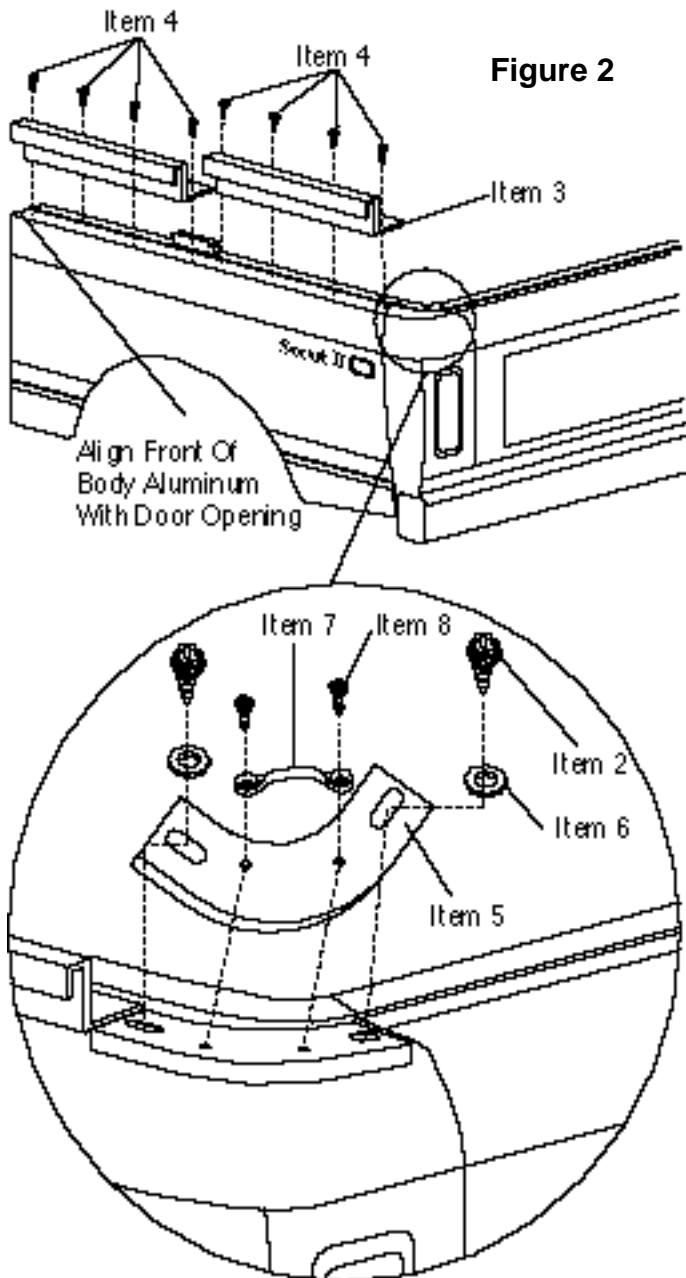

Figure 2

Step 3. Corner Plate. Butt corner plate (Item 5) next to rear body aluminum. Mark and drill 5/32" holes using large holes in corner plate as a template. Secure to body with #14 x 1/2" sheet metal screws (Item 2) through 1/4" flat washers (Item 6) and into vehicle body. Drill 1/8" holes using small holes in corner plate as a template. Place footman loop (Item 7) over these holes and secure to body with #8 x 1/2" oval head sheet metal screws (Item 8). Repeat for the other side. See figure 3.

Step 4. Tailgate Clip. Measure 2" from edge of tailgate and mark location of tailgate clip (Item 9). Using tailgate clip as a template mark and drill 1/8" holes making sure that there is a 3/16" gap between tailgate and bottom of tailgate clip. Secure to tailgate with #10 x 1/2" sheet metal screws (Item 4). Repeat for the other side. See figure 3.

Step 5. Bows. Secure bow release (Item 11) to rear set of holes in bow mount by placing 1/4-20 x 1 1/2" hex head bolt (Item 12) through one side of bow mount, bow release bracket and through other side of bow mount. Secure with 1/4-20 lock nut (Item 13). These items must pivot so do not over tighten. Repeat for the other side. Place bow sleeve (Item 14) over rear bow halves (Item 15). Place rear bow into bow release bracket. Place 1/4-20 x 1 1/2" hex head bolt (Item 12) through center hole in bow release bracket, rear bow and through other side of bow release bracket. Secure with 1/4-20 lock nut (Item 13). Again these items must pivot so do not over tighten. Place bow sleeve (Item 14) over front bow halves (Item 16). Place front bow into front holes in bow mount with large holes in front bow are facing forward. Secure to bow mount by placing 1/4-20 x 1 1/2" hex head bolt (Item 12) through one side of bow mount, front bow and through the other side of bow mount. Secure with 1/4-20 lock nut (Item 13). Again these items must pivot so do not over tighten. Repeat for the other side. See figure 3.

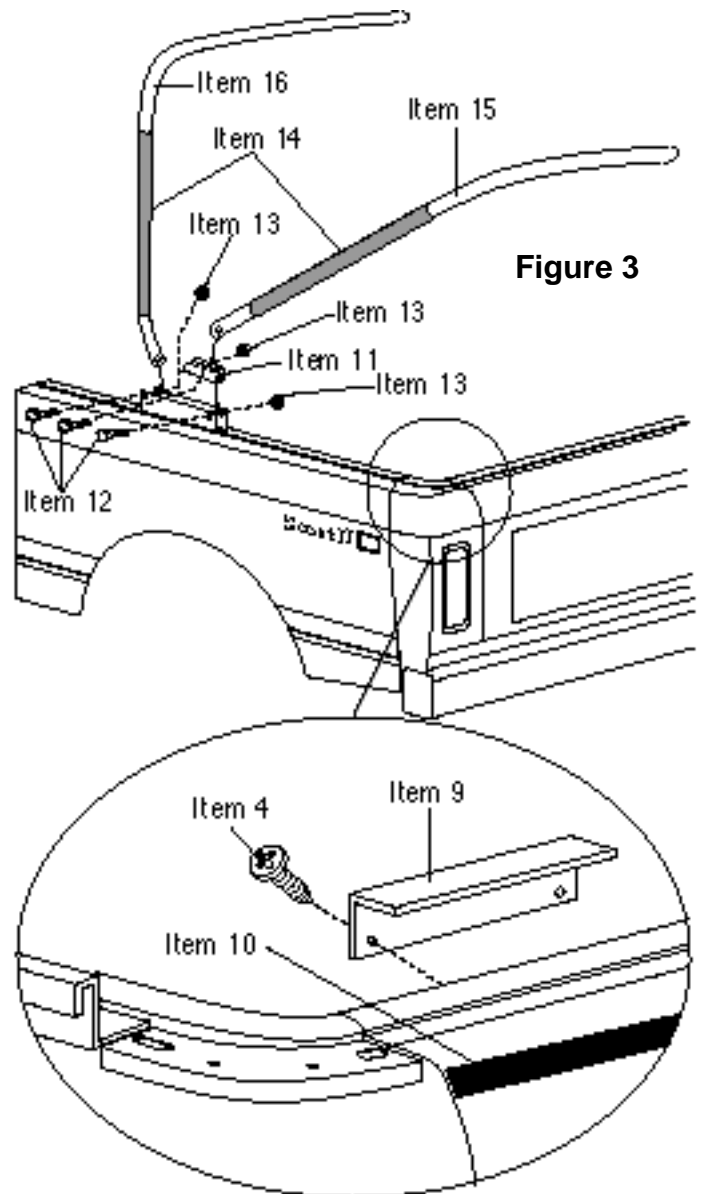
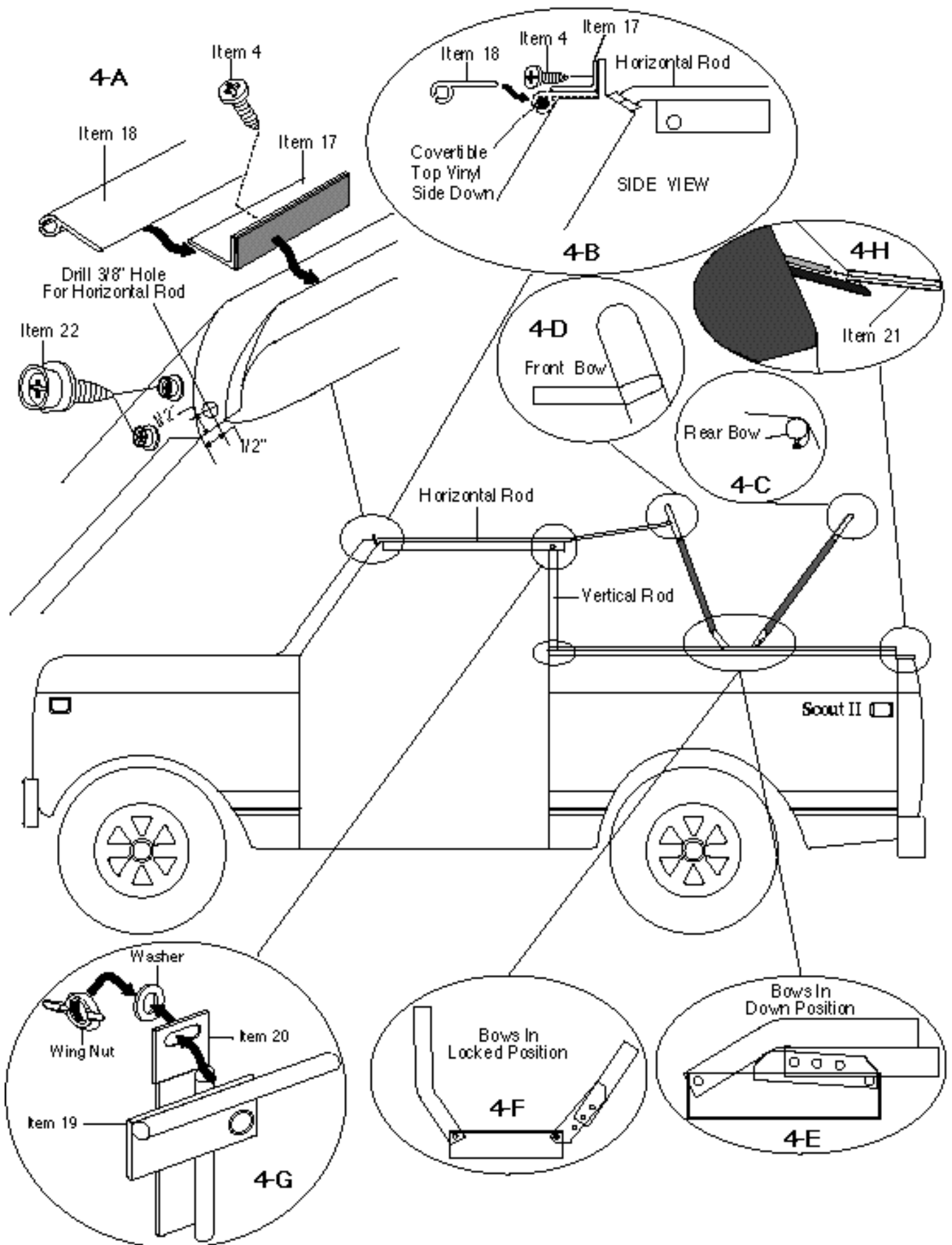

Figure 3



Step 6. Windshield Slot. Position windshield slot (Item 17) on top of windshield frame centered from side to side, and with the weather stripped edge toward the vertical flange on top of frame. Place windshield channel (Item 18) under windshield slot. The channel will act as a shim to provide proper clearance between windshield frame and windshield slot. Starting at the center, mark and drill 1/8" hole. Secure slot to flange on windshield frame with a #10 x 1/2" sheet metal screws (Item 4). Mark drill and install sheet metal screws in remaining holes following same procedure as above making sure that gap between windshield slot and windshield frame remains the same from side to side. Windshield channel should slide under windshield slot easily with little resistance. Form ends of slot around flange on windshield frame. See figure 4-A and 4-B.

Step 7. Horizontal Rods. Measure 1/2" in from side of windshield frame and 1/2" in from inside of windshield frame. Mark and drill 3/8" hole. See figure 4-A. While pulling front bow forward, place front of horizontal rod (Item 19) into hole in windshield frame. Place the rear of horizontal rods into hole in front bow. See figure 4-B and 4-D. Repeat for the other side. There is one left and one right horizontal rod. The right is painted white on the end that is placed into hole in windshield frame. Repeat for other side.

Step 8. Vertical Rods. With door closed, find position of vertical rod (Item 20) by holding it in place at rear of door frame vertical to the horizontal rod. Mark and drill 3/8" hole in body at this point. Remove washer and wing nut from horizontal rod. Place vertical rod into hole drilled in body and over bolt on horizontal rod. Attach vertical rod to horizontal rod with washer and wing nut previously removed. Repeat for other side. Again the right side vertical rod is marked white at the end that is placed into hole in body. See figure 4-G.

FABRIC INSTALLATION

Step 1. Channel Installation. Place top on hood of vehicle, vinyl side down. Slide sewn in rope (at front of top) into windshield channel (item 18). See figure 4-B. Slip channel under windshield slot. Flip top up and over bows. Snap rear bow flap to rear bow. See figure 4-C.

Step 2. Top Installation. Pull to the rear and down on rear bottom corners of side panels until 2 1/2" pieces of plastic are fully engaged on corner plate. See figure 5. Clip long plastic pieces from rear to front until all are fully engaged on body aluminum. Insert tailgate retainer (Item 21) into fabric loop on rear curtain. See figure 4-F. Slip tailgate retainer between tailgate clips and tailgate. See illustration 4-H. Lock rear bows into position as shown in illustration 4-F. Thread buckle straps through footman loops. Tighten only enough to hold rear bow in place. See figure 5. If over tightened, it could cause top to tear or strap to be pulled from top. Close zippers on both sides of rear curtain.

If top is too tight and you are unable to clip plastic to corner plates or body aluminum it may be necessary to remove your horizontal and vertical rods to allow the front bow to fall forward and relieve tension on the top. After removing horizontal and vertical rods clip plastic to corner plates and body aluminum. Once all plastic is clipped into place, push front bow to the rear and install horizontal and vertical rods. Then proceed as directed above. After initial installation the top should form to hardware and installation should become easier.

Step 3. Horizontal And Vertical Flaps. Wrap vertical rod flap around vertical rod and press hook and loop together. Wrap horizontal rod flap around horizontal rod and press hook and loop together.

Step 4. Snap Stud At Windshield Corner. Locate for snap stud (Item 22) by pulling forward and down on front of convertible top. Mark and drill 1/8" holes. Install 3/8" sheet metal screw studs and snap top to studs. Repeat for the other side. See figure 4-A.

Figure 5

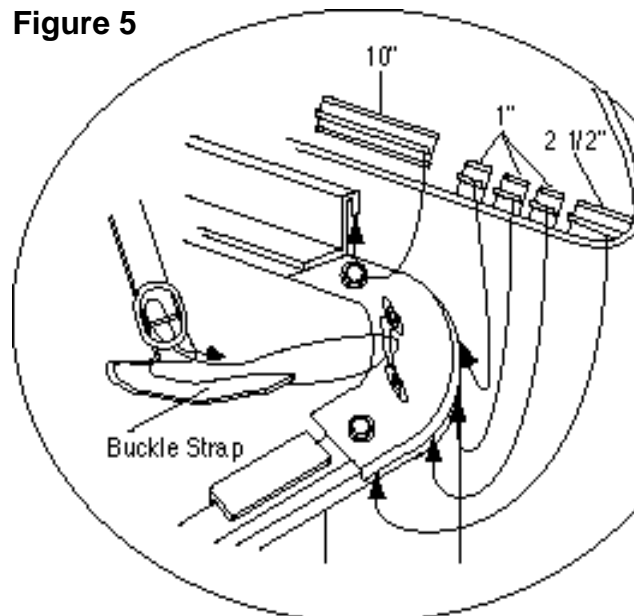

Rolling Up Side Panels. It is possible to roll up your side panels and rear curtain to provide more ventilation in your vehicle. Prior to rolling up side panels or rear curtain you must first make sure that windows are clean. If not properly cleaned, dirt will scratch them reducing the life of your top. It is also recommended that you use a soft cloth between the windows and the retaining straps to prevent them from marring the glass. To clean the windows, wash them with a mild non-detergent soap and water. To roll up side panels first unzip rear curtain and unlock rear bow. Unfasten side panel from body aluminum, roll up side panel and secure with retaining strap. See figure 6. Lock rear bow and tighten buckle strap to retain tension on convertible top. Follow same procedure to roll up rear curtain, first removing tailgate retainer. You may roll up both side panels and rear curtain if you wish.

FOLDING INSTRUCTIONS

Step 1. Unlock rear bow and unfasten sewn in plastic from body aluminum. Lift side panels and fold on top of bows.

Step 2. Remove tailgate retainer. Lift rear curtain and fold on top of side panels (on top of bows).

Step 3. Remove horizontal and vertical rods. Fold front of top to the rear.

Step 4. As you pull the front of top to the rear of vehicle fold as you go until you have it neatly folded at the tailgate. A convertible boot is available from your dealer to enclose your top preventing it from getting dirty while in the down position. If you intend to leave the top down for an extended period of time it is recommended that you place a soft cloth between the windows and vinyl material to prevent window discoloring.

Figure 6

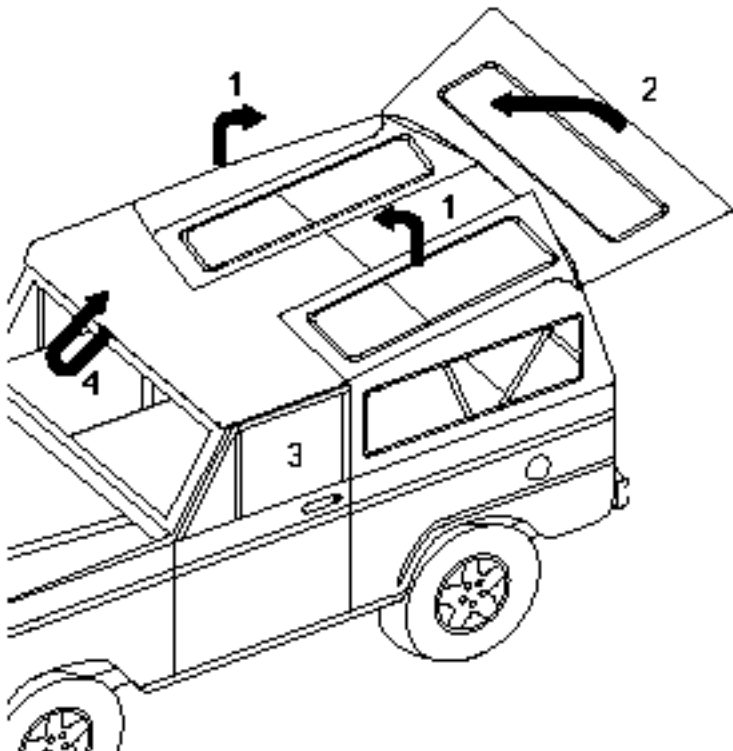
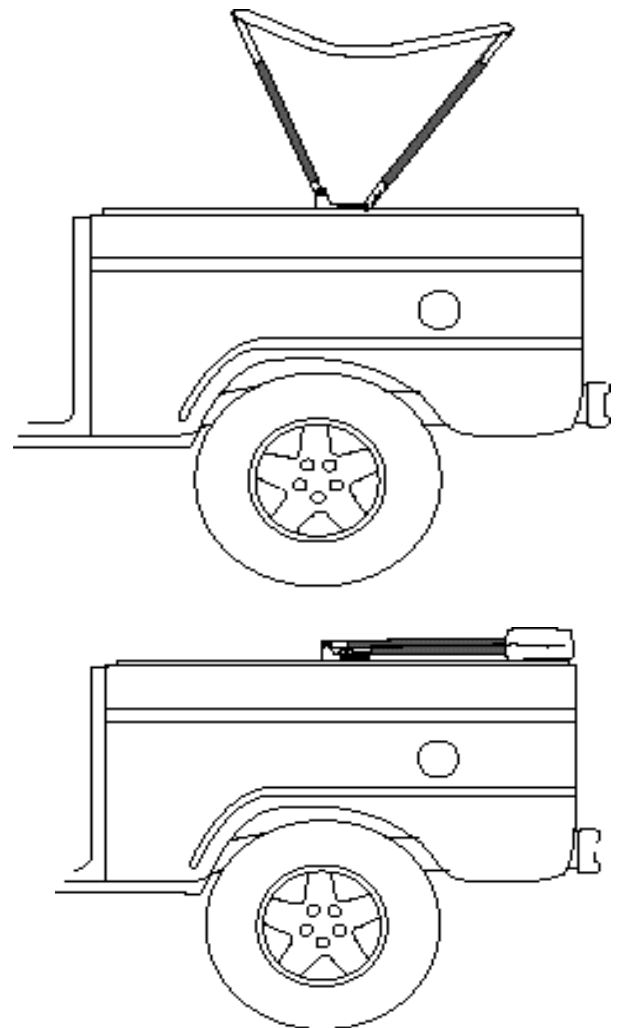
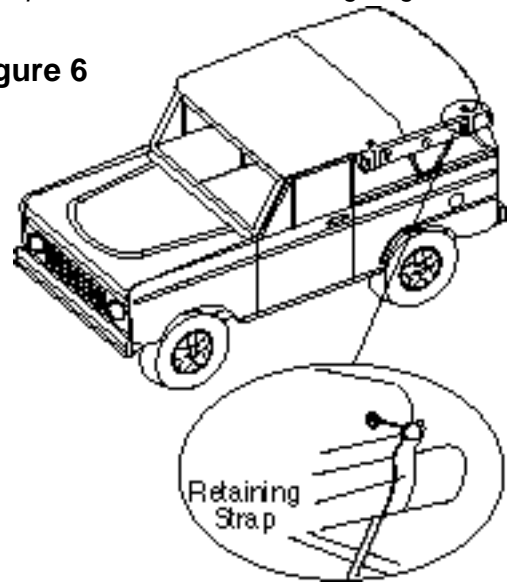

Parts Identification And Requirements

Item 1
Bow Mount Bracket
2 Required

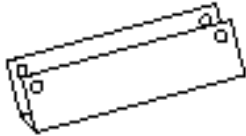

Item 2
#14 x 1/2"
Sheet Metal Screw
8 Required



Item 3
Body Aluminum
4 Required

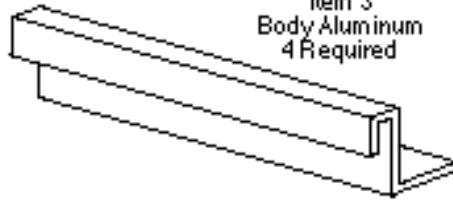

Item 4
#10 x 1/2"
Sheet Metal Screw
25 Required



Item 5
Corner Plate
2 Required



Item 6
1/4" Flat Washer
4 Required



Item 7
Footman Loop
2 Required

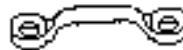

Item 8
#8 x 1/2" Oval Head
Sheet Metal Screw
4 Required



Item 9
Tailgate Clip
2 Required

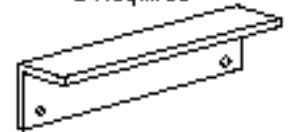

Item 10
1" Hook
1 Piece 53"



Item 11
Bow Release
2 Required



Item 12
1/4-20 x 1 1/2"
Hex Bolt
6 Required



Item 13
1/4-20 Lock Nut
6 Required



Item 14
Bow Sleeve
4 Required

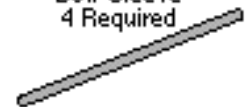

Item 15
Rear Bow
2 Halves

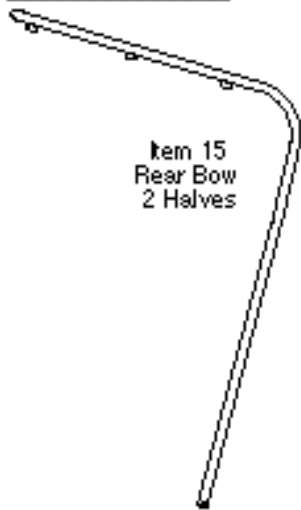

Item 16
Front Bow
2 Halves

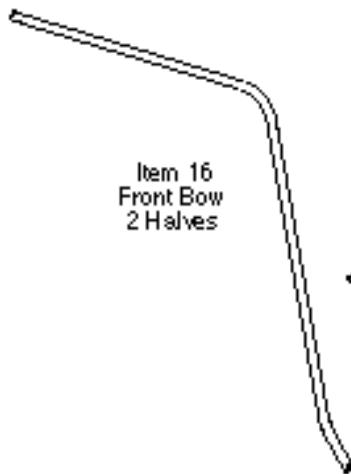

Item 17
Windshield Slot
1 Required

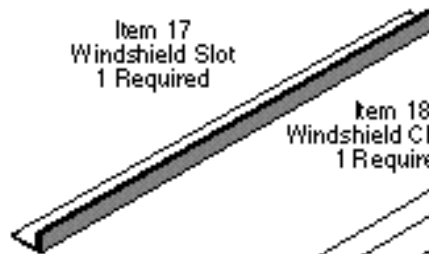

Item 18
Windshield Channel
1 Required

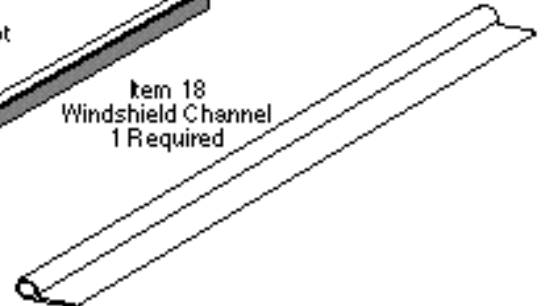

Item 19
Horizontal Rod
With Washer And Wing Nut
1 Left Shown, 1 Right



Item 20
Vertical Rod
1 Left Shown, 1 Right

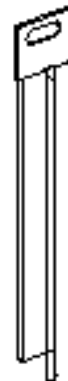

Item 21
Tailgate Retainer
1 Required

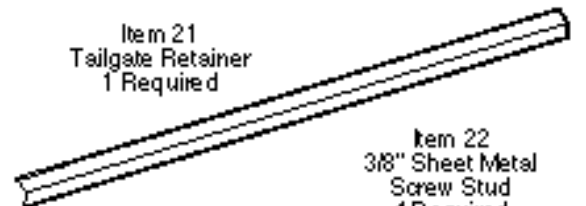

Item 22
3/8" Sheet Metal
Screw Stud
4 Required



CARE INSTRUCTIONS

Convertible tops and accessories require special care if you want to get the maximum usage and enjoyment from them. The following recommendations, if followed carefully, can extend the life of your top or accessory.

1. Hand wash using a mild non-detergent soap such as Ivory. Use a nonabrasive cloth or sponge. Rinse thoroughly.
2. **DO NOT** wash in direct sunlight and avoid automatic car washes.
3. When your top is clean, we recommend using "303 Protectant" on both the vinyl top and windows. This product contains a sunscreen that helps protect from the sun's damaging rays. Stay away from products containing alcohol as it will cause the fabric and windows to lose their elasticity, thus reducing the life of your top or accessory. If you are unable to locate "303 Protectant", please call 1-800-223-4303 for a distributor near you.
4. Direct sunlight and heat are the biggest enemies of the windows. Park in the shade whenever possible. If you must park in the sunlight, rotate the direction that you park every few days so all windows get even exposure.
5. Our tops are designed so that you may roll up and/or store the rear curtain and side curtains. To prevent scratching of the windows, be sure that windows are completely clean and free of dust particles. Even a little dirt will badly scratch the windows. You may want to use a soft cloth when rolling up or storing your windows. Heat may build up on rolled up windows, so be sure to unroll them frequently. If you roll up the windows at the beginning of summer and leave them, they may be ruined by fall.
6. **DO NOT** open or roll up windows at temperatures below 45 degrees F. This could cause them to crack or break.
7. **NEVER** use ice scrapers or snow brushes on vinyl windows.

WARRANTY INFORMATION:

Specialty Top Co. manufacturing warrants to the original purchaser of any product it manufactures, that the product will be free of defects in material or workmanship for a period of 90 days from date of purchase. Such obligations under this warranty shall be limited to the **repair or replacement**, at Specialty's discretion, of any assembly or parts which upon examination by Specialty Top Co. proves to be defective. All defective items must be returned with proof of purchase to Specialty Top Co. Manufacturing, 200 East 64th Avenue, Denver, Colorado 80221, freight prepaid. This warranty does not cover damage resulting from abuse, misuse, alteration, accident or damage in transit. Specialty's obligations under this warranty are limited to the aforementioned repair or replacement of warranty defects for which the return authorization has been received during the warranty period, and **SPECIALTY TOP CO. SHALL NOT BE LIABLE FOR ANY INCIDENTAL OR CONSEQUENTIAL DAMAGES ARISING FROM BREACH OF THIS OR ANY IMPLIED WARRANTY.**

Some states do not allow the exclusion or limitation of incidental or consequential damages, so the above limitation or exclusion may not apply to you. This warranty gives you specific legal rights, and you may also have other rights which may vary from state to state.

If you need assistance or further information, you may contact Specialty Top Co. at 1-866-487-9944 between the hours of 8:00 AM and 5:00 PM, Monday through Friday, Mountain Standard Time.