



SPECIALTY TOP CO.

INSTALLATION INSTRUCTIONS BRONCO 1980-1991 PART #334-31X

Thank you for purchasing Specialty's Convertible Top for your Bronco. It has been designed for great fit and long wear. Please read and follow, precisely, all installation instructions provided when installing top. Failure to do so may result in a poor fitting top and could place occupants in a potentially hazardous situation.

TOOLS REQUIRED:

3/8" WRENCH	HAMMER
1/2" WRENCH	PLIERS
2-7/16" WRENCHES	RATCHET HANDLE
ELECTRIC DRILL	1/2" SOCKET
5/32" DRILL BIT	3/8" SOCKET
1/8" DRILL BIT	7/16" SOCKET
#2 PHILLIPS SCREWDRIVER	RUBBING ALCOHOL
FLAT BLADE SCREWDRIVER	
6' TAPE MEASURE	
CENTER PUNCH	

INSTALLATION TIPS

Before you begin installing this top, here are a few tips to make installation easier.

This top should be installed where the temperature is above 72 degrees Fahrenheit. Below this temperature, the top may contract making it difficult to install.

It is normal for a top to contract and wrinkle when stored in the shipping carton. The top will relax and wrinkles will disappear within a few days of installation as fabric adjusts to shape of mounting hardware.

INSTALLATION PROCEDURES:

Refer to page 6 to assure that all parts are included in your kit. Refer to diagrams on pages 3, 4, 5, 7, and 8 for help when installing top and hardware.

Step 1. Body Aluminum Clips. If you have the clips that came with the vehicle already in place then you can use those clips and go to step 2 To Install the body aluminum you will need to use the body aluminum clips. **Item #5.**

To install the clips, carefully put the clip in the square hole and push it until it clips into place over the round hole. Install three clips on both sides as seen in **Figure 1.**

Step 2. Rear Body Aluminum. To install the body aluminum you will need a 1/2" wrench or socket, a 3/8" wrench or socket, an electric drill with a 5/32" bit, a flat blade screwdriver, and the ratchet handle. **For installation see to Figure 2 on page #3.** First install the rear body aluminum (**item #1**). The rear body aluminum is the one with the notch that closely matches the notch at the rear end of the vehicle. Install the body aluminum with the black foam weatherstrip out and the bolt and wingnut on the notched end at the rear. **See figure 2.** Put the first bolt (**Item #2**) through the washer (**item #3**) then through the large pre-punched hole in body aluminum and into the rear threaded hole in body. Make sure the notch in rear body aluminum closely aligns with notch in the rear of body. **Do not fully tighten bolt.** Install the second bolt (**Item#2**) through the washer (**item #3**) and through the hole in body aluminum and into the body aluminum clip installed in step 1. **Do not fully tighten bolt.** Now carefully slip nylon spacer (**item #15**) under rear body aluminum making sure to align it with the pre-punched small hole in the

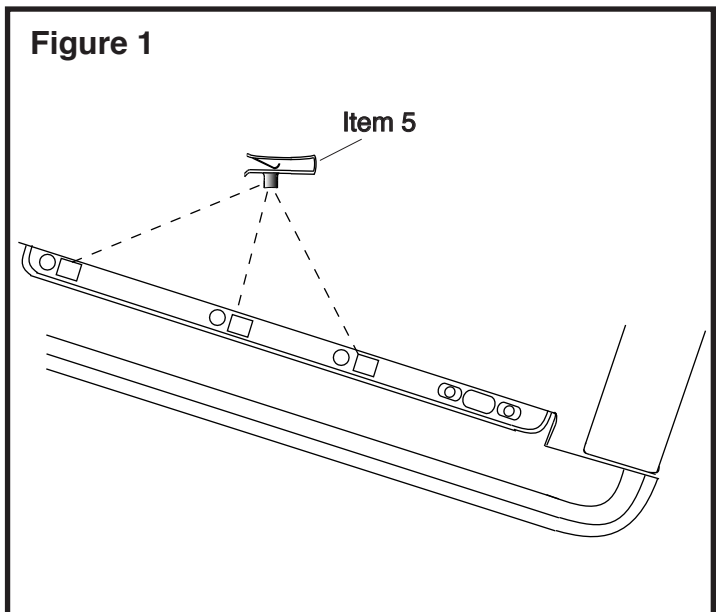

rear of the rear body aluminum. **Now tighten both bolts using the 1/2" wrench or socket.** Now using the pre-punched small hole in the rear of the rear body aluminum as a guide, drill a 5/32" hole into the body through this hole. **See Figure 2.** Install the sheet metal screw (**item #10**) through the pre-punched hole and the nylon spacer (**item #15**) and into hole drilled in body. **Do not fully tighten screw. Now loosen other two bolts tightened earlier.**

Step 3 Front Body Aluminum. The front body aluminum (**item #4**) is installed with the black foam weatherstrip out and the curved end with the rivet towards the front. **See figure 2** Align the pre-punched half moon hole in the front body aluminum with the pre-punched half moon hole in the rear body aluminum. Install bolt (**item #2**) through washer (**item #3**) and through body aluminum and into clip (**item #5**) installed earlier. **Do not tighten bolt.** Finally, install the last bolt (**item #2**) through washer (**item #3**) through hole in the front body aluminum and into (**clip #5**). **Do not tighten bolt. See figure 2.** Now align all body aluminum and **using the 1/2" wrench or socket tighten all bolts.** Then using the flat blade screwdriver or the 3/8" wrench or socket tighten the sheet metal screw (**item #10**) installed earlier. **Don't over tighten this screw as it may strip out! Follow the same instructions for the other side body aluminum.**

Step 4 Bow Mount. You will need the tape measure, the electric drill with the 5/32" drill bit, and the flat blade screwdriver or the 3/8" socket. Measure 27" from the rear notch in the rear body aluminum and place the bow mount (**item #8**) at this point. The rear edge of the bow mount should be at 27". **See Figure 3.** With the bow mount flush with the inside edge of the body aluminum, using the bow mount as a template, mark one hole in the front of the bow mount and one in the rear. Now drill these holes using the 5/32" drill bit. **Only one front hole and one rear hole is needed to secure the mount.** Secure the mount (**item #8**) to the top of the body with the sheet metal screws (**item #9**). Tighten using the flat blade screwdriver or the 3/8" socket. **See Figure 3. Don't overtighten these screws or they may strip out!**
Follow the same instructions for the other bow mount.

Step 5 Cab Aluminum. You will need the center punch and hammer, the marker, the electric drill with 1/8" drill bit, the #2 phillips screwdriver and the tape measure.

To install the cab aluminum (**item #'s 23 and 24**) refer to **Figure 4 on page #4.**

Start with either side cab aluminum but only install one side at a time.

Position cab aluminum (**item#23**) with the grey foam weatherstrip down and the slot in the cab aluminum facing towards the cab **see figure 4.** Position it in the body channel behind the cab as seen best in **Figure 4-D.** **Align the top corner of the cab aluminum first.** The top corner of the cab aluminum above the corner hole in the cab aluminum must align with the corner of the cab. **See Figure 4.**

The front edge of the cab aluminum top corner should be as close to flush as possible with the corner contour of the cab. See Figure 4-A. You will need someone to hold this cab aluminum piece in place while marking the cab in the corner, through the corner hole in the cab aluminum, with the marker. **Make sure that the corner of the cab aluminum remains flush with the corner of the cab and is centered in the corner.** Center punch this hole. Now drill a 1/8" hole on this mark and install the cab aluminum (**item#23**) in the corner with the sheet metal screw (**item #6**) using the phillips screwdriver. **See Figure 4.**

5A:Next, using the tape measure, measure 1 1/2" inches from the bottom of the body channel to the top of the cab aluminum channel you just installed. **Measure on the end of the cab aluminum only. See Figure 4-B** Then while holding the cab aluminum at this 1 1/2" inches, mark the cab through the end hole in the cab aluminum at this point. Center punch this hole. The drill an 1/8" hole and using the phillips screwdriver install the sheet metal screw (**item #23**) through end hole in the cab aluminum.

5B:Next, using the tape measure, measure 1/4" inch in from the edge of the cab at the bottom of the cab aluminum. **You may need to push the bottom edge of the cab aluminum in a little to get it to 1/4" inch. See Figure 4-C.** While holding cab aluminum at this 1/4" inch point, mark the cab through the bottom hole in the cab aluminum. Center punch this hole if possible. Then drill an 1/8" hole and using the phillips screwdriver install the sheet metal screw (**item #23**) through the bottom hole in the cab aluminum. **See Figure 4.**

5C:Next, using the remaining holes in the cab aluminum as a guide, drill the 7 other 1/8" holes into the cab. **See Figure 4.** Using the phillips screwdriver install the 7 sheet metal screws (**item #23**) into the holes drilled in the cab. **See Figure 4.**

5D:Next take the other piece of cab aluminum (**item #24**) and align it at the top center with the first piece already installed. **See figure 4-D.** While holding the cab aluminum aligned with the other cab aluminum mark the end hole at this point. Center Punch. Then drill a 1/8" inch hole on this mark. Then using the phillips screwdriver install a sheet metal screw (**item #23**) through the end hole in the cab aluminum and into the hole just drilled.

Next as before align the corner of the cab aluminum so it is **flush with the corner contour of the cab see Figure 4A.** Mark and center punch and drill an 1/8" inch hole through the corner hole of the cab aluminum. Install the sheet metal screw (**item #23**) through the corner hole in the cab aluminum and into the cab.

Finally, follow steps 5B then 5C above to finish installing the remaining piece of cab aluminum.

Figure 2
Left Side Shown

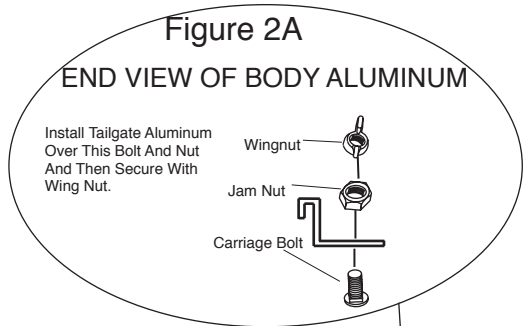
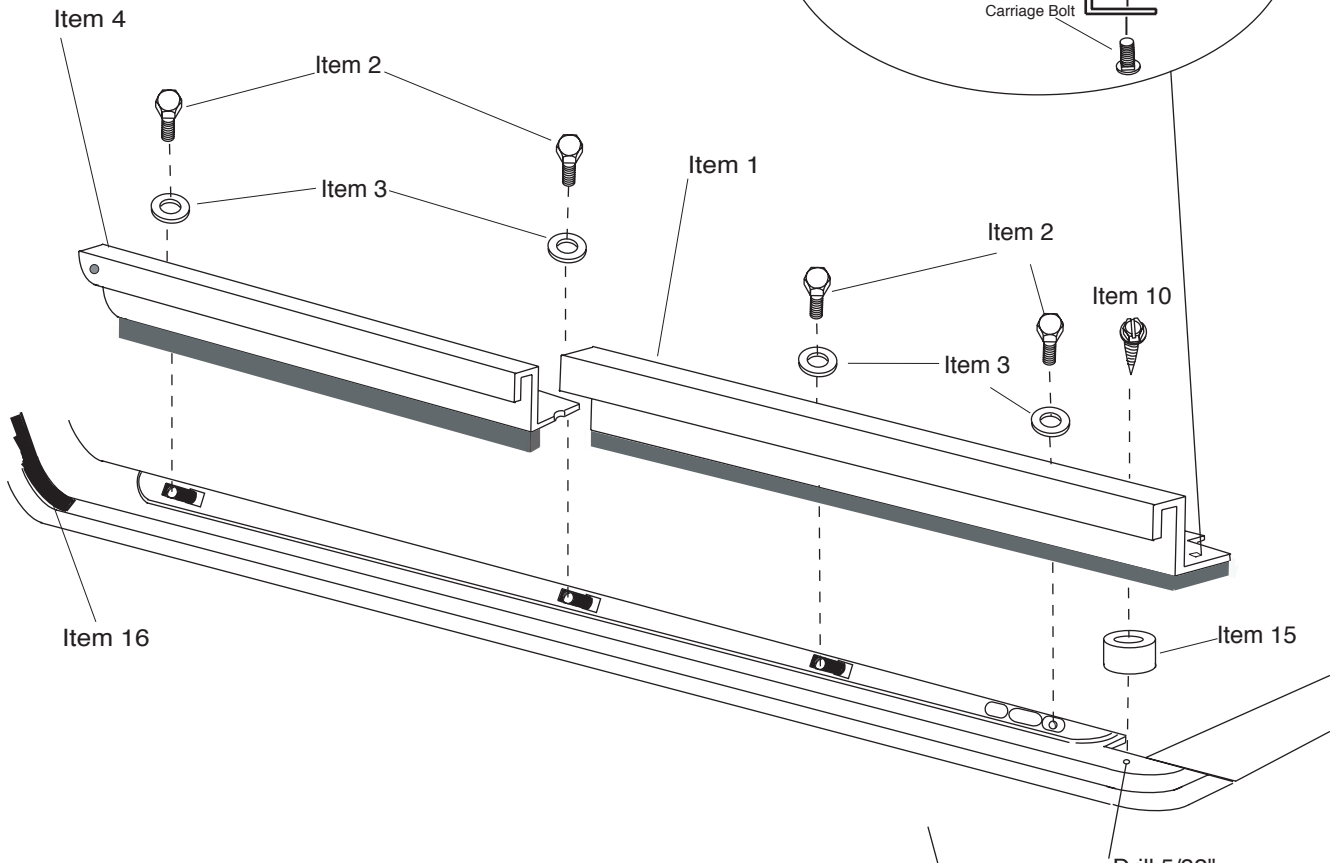
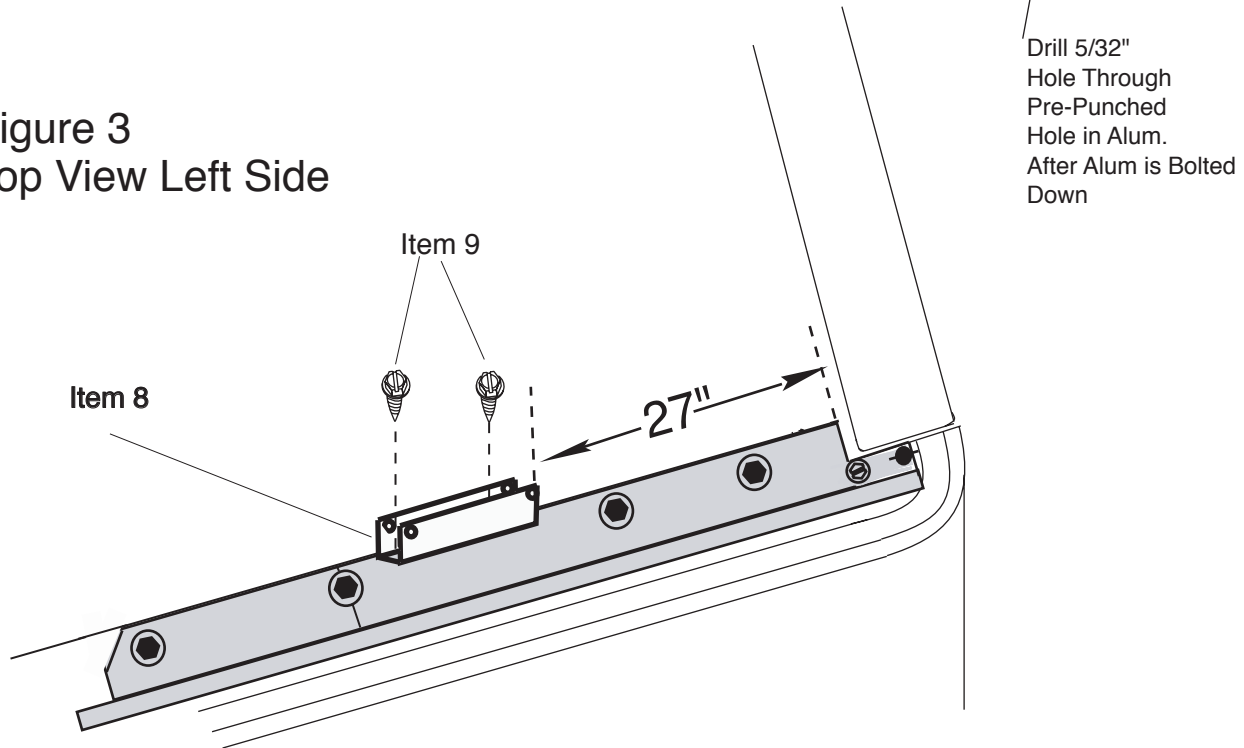
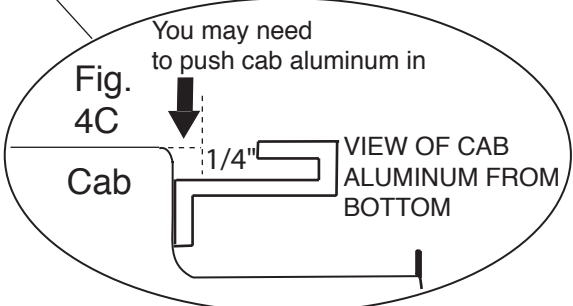
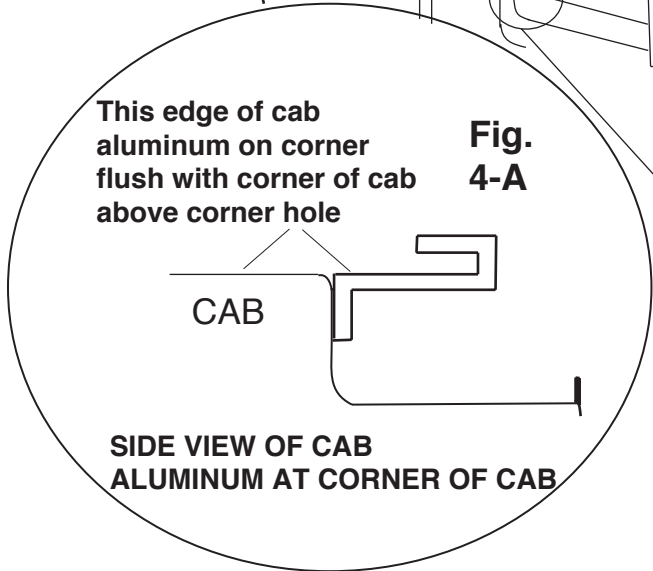
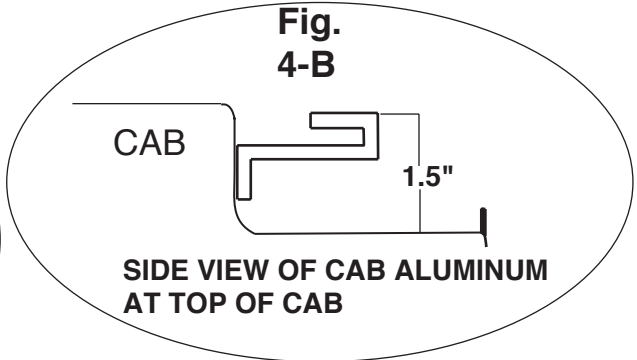
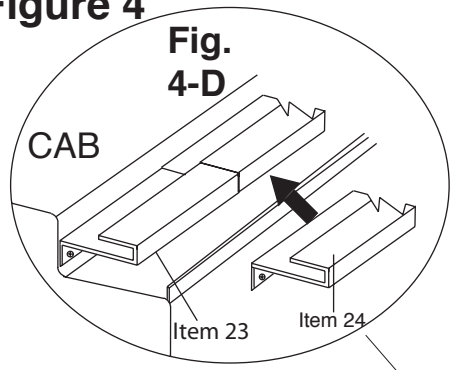
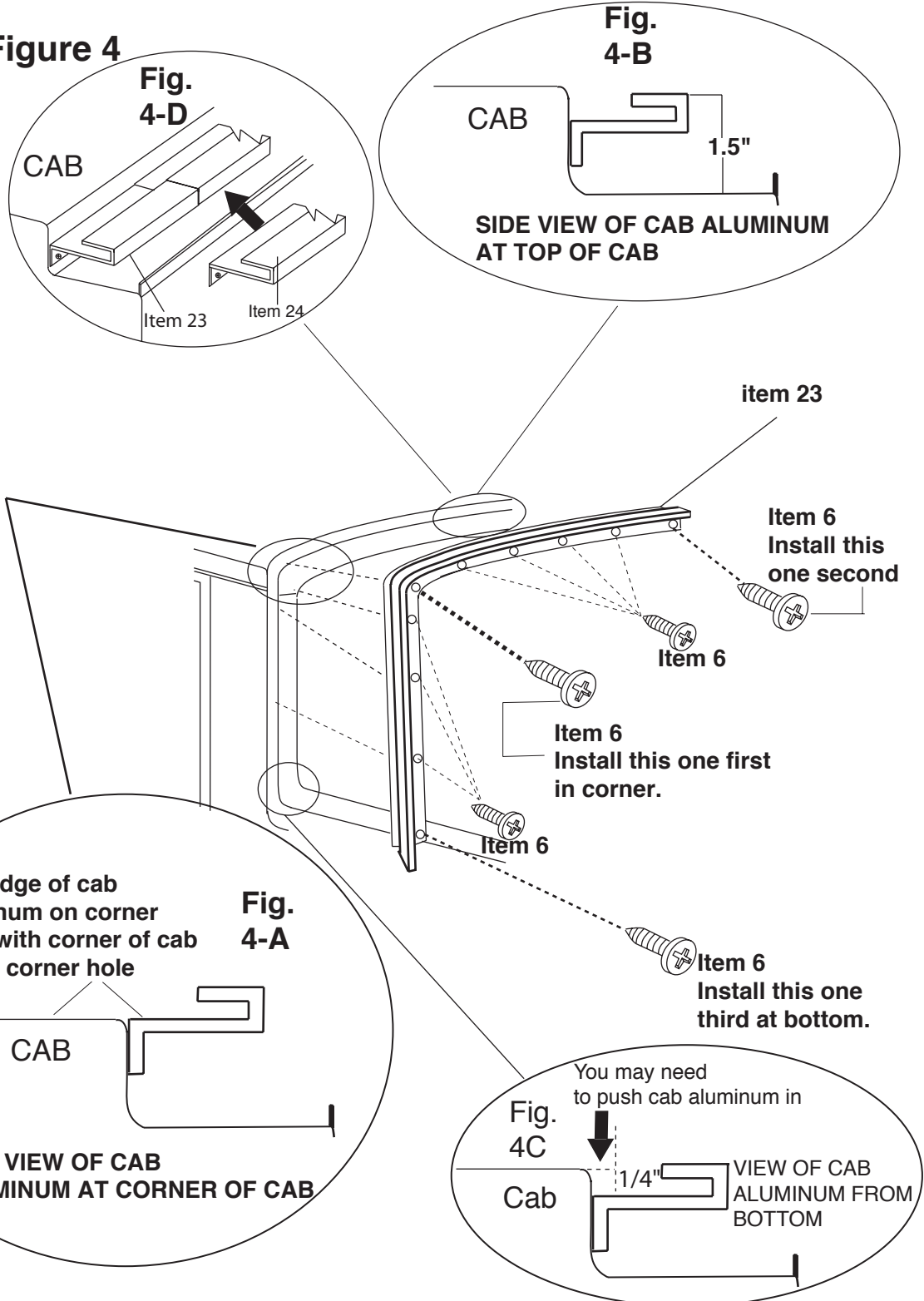

Figure 3
Top View Left Side



Left Side Cab Aluminum Installation Shown

Figure 4



item 23

Item 6
Install this one second

Item 6
Install this one first in corner.

Item 6
Install this one third at bottom.

Figure 5

Make sure to align the channels on the tailgate aluminum when putting tailgate aluminum pieces together. Put aluminum together before installing nuts & bolts and screws.

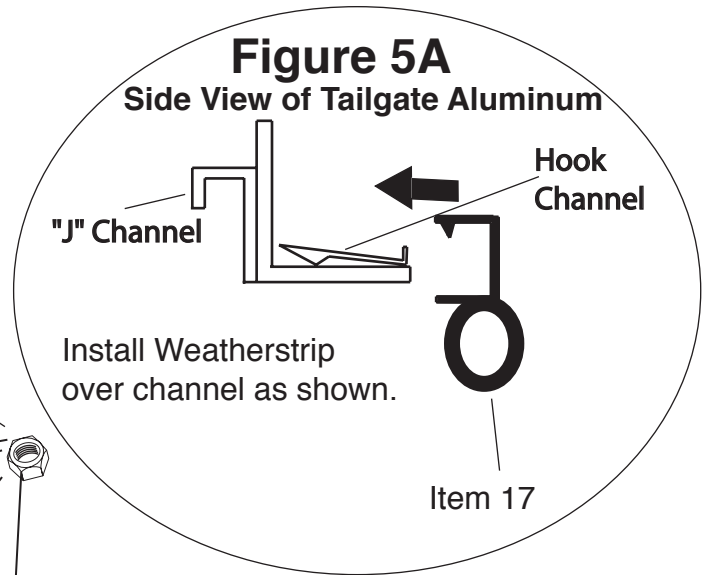
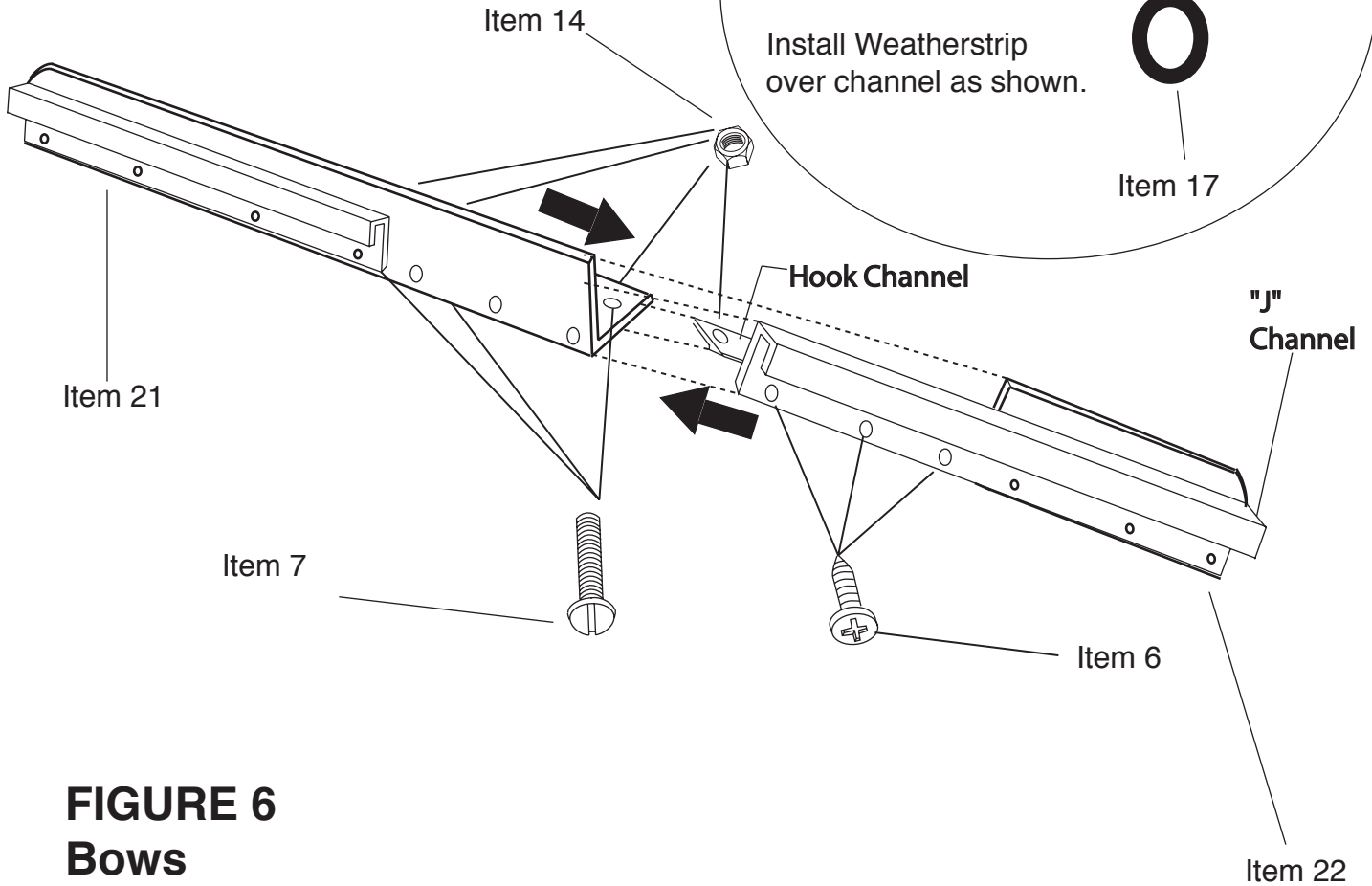
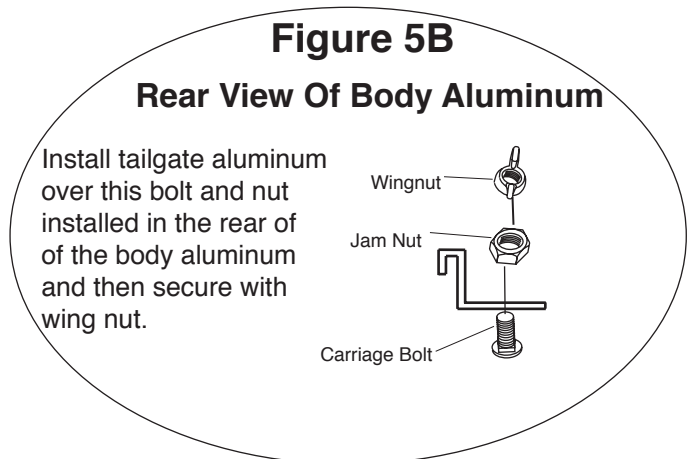
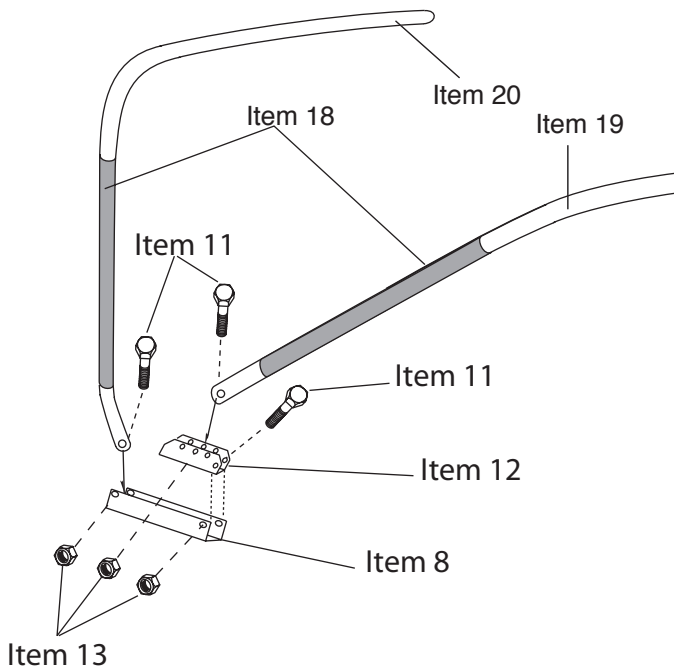
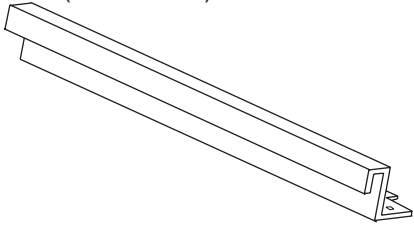

FIGURE 6 Bows



PARTS IDENTIFICATION

Item 1
Rear Body Aluminum
1 Left, 1 Right
(Left Shown)



Item 2
8 MM x 1.25 X 20 MM
Hex Bolt
8 Required

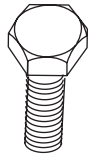

Item 3
5/16" Flat Washer
8 Required

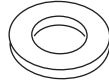

Item 4
Front Body Aluminum
1 Left, 1 Right
(1 Right Shown)

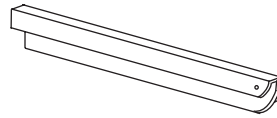

Item 5
M8 x 1.25
"CIP" U Nut
8 Required

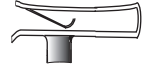

Item 6
#10 x 1/2"
Sheet Metal Screw
23 Required

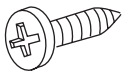

Item 7
#10-24 x 1/2"
Machine Screw
3 Required

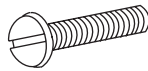

Item 8
Rear Bow Mount
2 Required

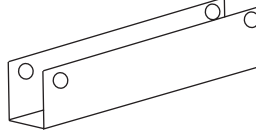

Item 9
#14 x 1/2" Sheet
Metal Screw
4 Required

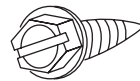

Item 10
#14 x 3/4" Sheet
Metal Screw
2 Required

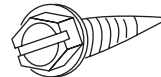

Item 11
1/4-20 x 1 1/2"
Hex Bolt
6 Required

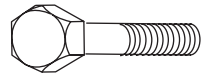

Item 12
Bow Release Bracket
2 Required

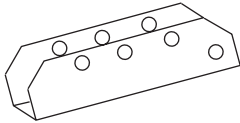

Item 13
1/4-20 Lock Nut
6 Required



Item 14
#10 - 24 Hex
Lock Nut (Nylon)
3 Required



Item 15
1/2" Round Nylon
Spacer
2 Required



Item 16
Sticktite
Weatherstrip
12" Required



Item 17
Trim
Weatherstrip
66 3/4" Required

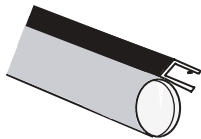

Item 19
Rear Bow
1 Left Shown - 1 Right

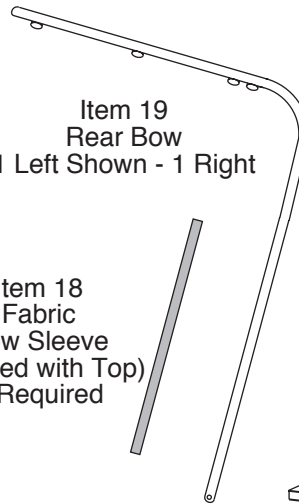

Item 20
Front Bow
1 Left Shown - 1 Right

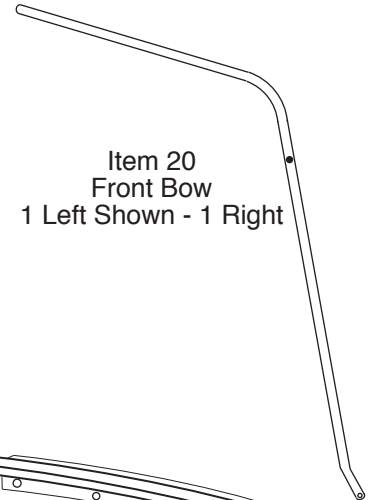

Item 18
Fabric
Bow Sleeve
(Packed with Top)
4 Required



Item 21
Tailgate Alum
Left Side

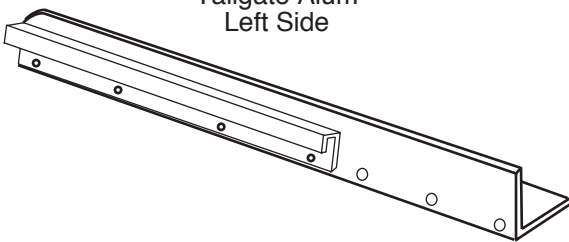

Item 22
Tailgate Alum
Right Side

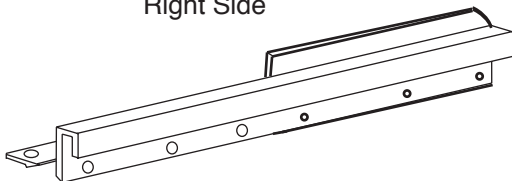

Item 23
Cab Alum
Left Side

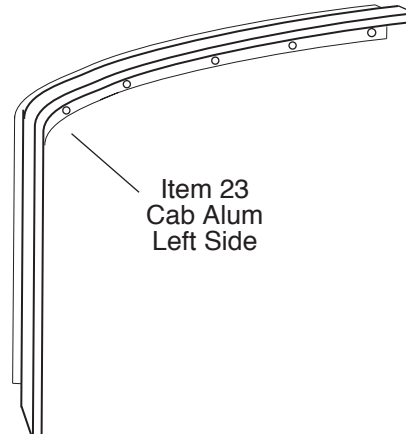

Item 24
Cab Alum
Right Side

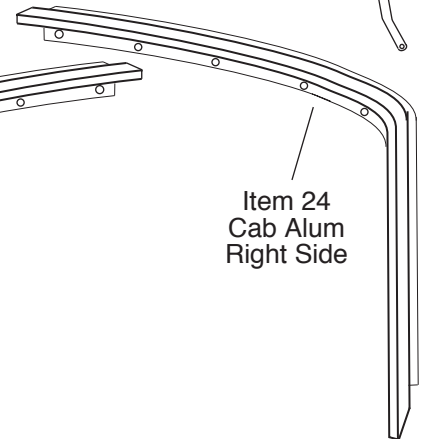
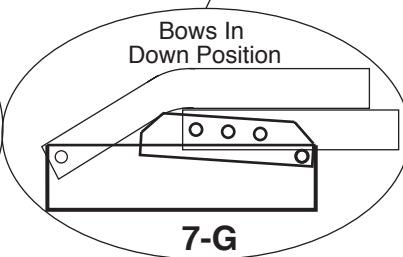
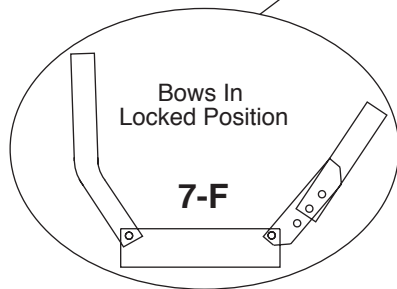
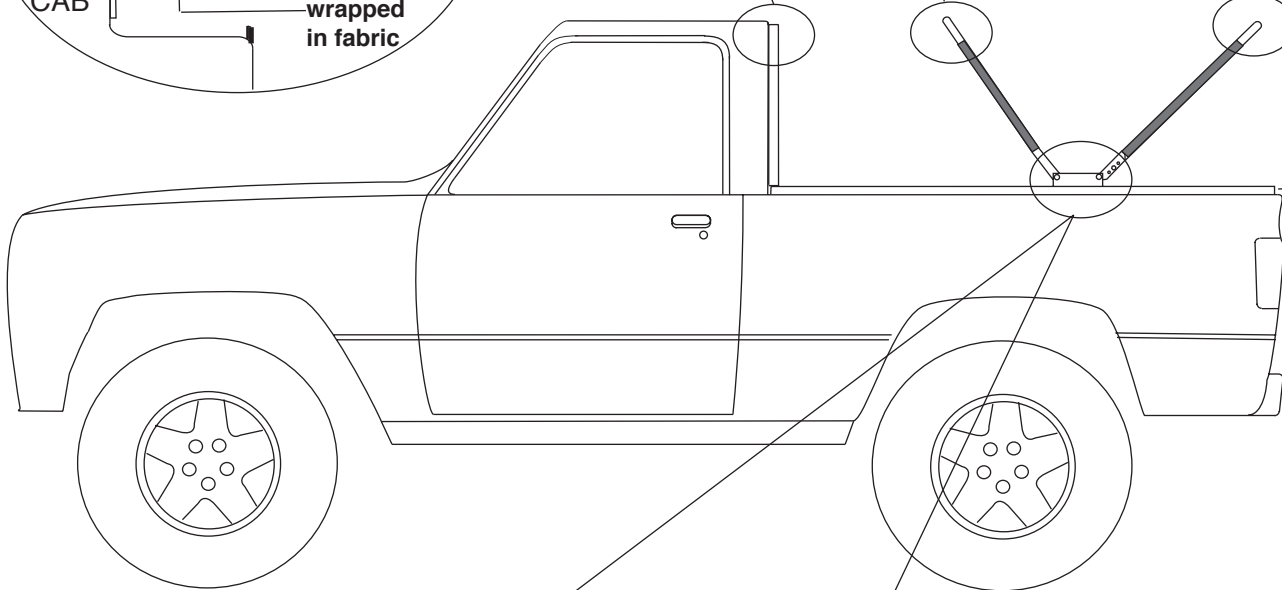
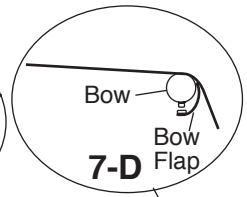
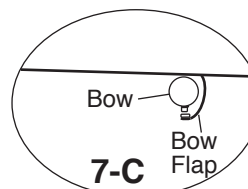
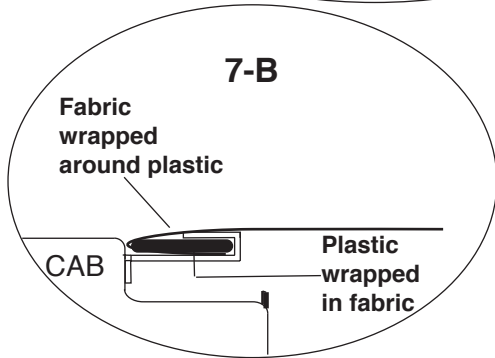
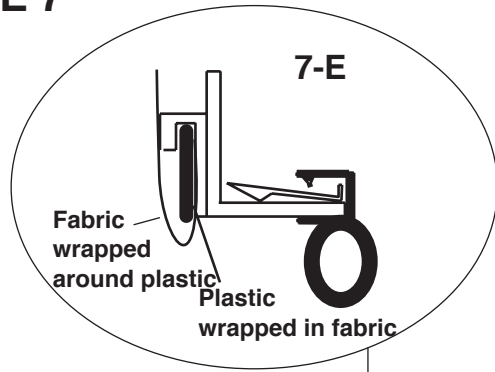
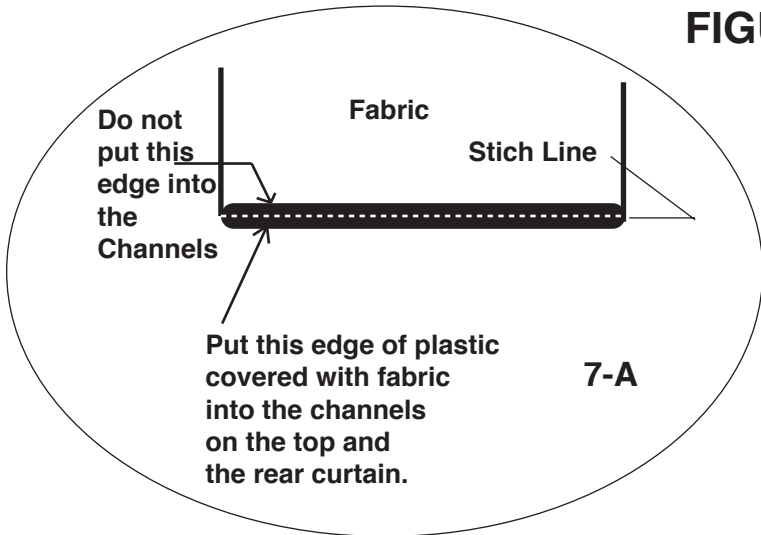

FIGURE 7



Fabric Installation

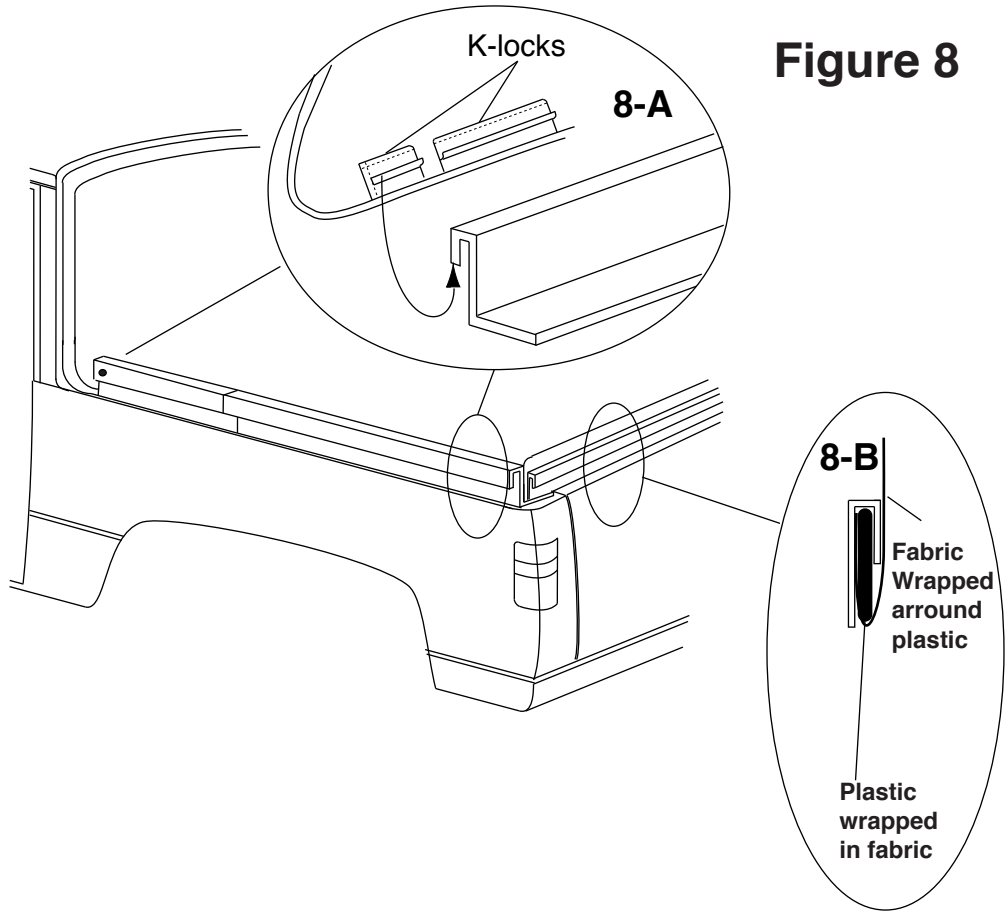
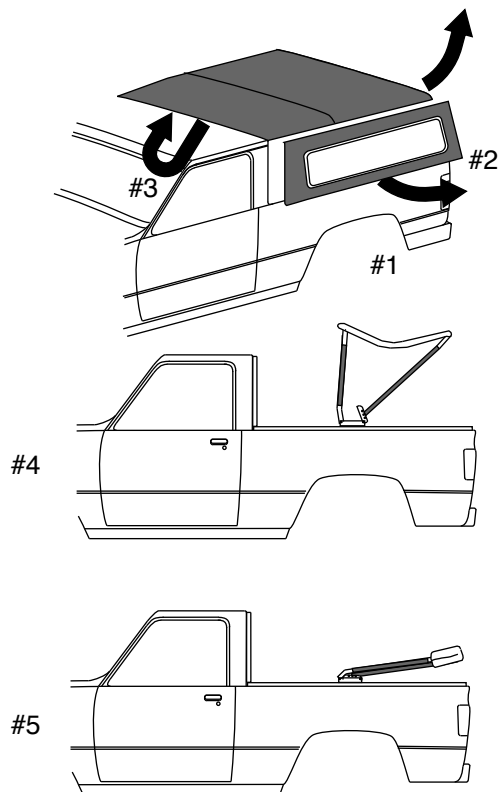

Figure 8

Folding Instruction

Figure 9



Step 6 Tailgate Aluminum Assembly. For help refer to **Figure 5 on page 5** To put together the tailgate aluminum you will need the straight blade screwdriver, the phillips screwdriver and the 3/8" wrench or the 3/8" socket and the ratchet. First slide the short or right tailgate piece, **(item #22)** onto the long or left tailgate piece, **(item #21)**. **Make sure that the "J" channels line up and that the hooked channels line up. See Figure 5.** Then install the 3 bolts, **(item # 7)** through the tailgate angle and the hooked channel from the bottom. Then secure, using the 3/8" wrench or socket and the flat blade screwdriver, with the 3 nylon locknuts, **(item #14)** see **figure 5**. Then using the phillips screwdriver, install the 3 sheet metal screws, **(item #6)** though the "J" channel and the tailgate angle. The heads of the screws should come out under the hooked channel. **Note: if you have access to a rivet gun or hand riveter you can install rivets through the holes where the bolts and nuts and screws go.**

Step 7 Weatherstrip installation. Install the weatherstrip, **(item #17)** over the hooked channel on the the tailgate aluminum. **See figure 5A.** Make sure that the round rubber part of the weatherstrip goes down. The weatherstrip should go from end to end over the hooked channel. Press the weatherstrip trim piece over the hooked channel and then squeeze it together to hold it tight. **Note: for a even more secure fit you can apply a good quality auto trim adhesive to the hooked channel and the weatherstrip and then apply the weatherstrip.**

Step 8 Install the Tailgate aluminum. To install the tailgate aluminum you may need to have some pliers. First unscrew the wingnuts on either side of the rear body aluminum. **Make sure the tailgate is closed when installing the tailgate aluminum.** Place the two large pre-punched holes in the tailgate aluminum over the two bolts in the rear body aluminum, on top of the large jam nuts and the two weatherstrip sections on the rear body aluminum. **See figure 5B or 2A.** Make sure the "J" channel is facing out towards the rear of the vehicle. **See Figure 8.** Now press the tailgate aluminum down and tighten the wingnuts on both sides. **Note: You may need to use pliers to tighten the wingnuts. Be careful with the tailgate aluminum if you leave it on with the tailgate open as leaning on it or pulling on it could bend it or break it. It is best to remove it if you are going to leave the top down for an extended period of time. Do not climb on it or sit on it as this may bend or break it. In general, with the top down, it would be best to remove the tailgate aluminum.**

Step 9 Install bows into bow mount. For help refer to **figure 6 on page 5 and figures 7, 7-F and 7-G on page 7.** To install the bows you will need the two 7/16" wrenches, or the the 7/16" wrench and the 7/16" socket and ratchet. Install the bow release brackets, **(item # 12)** into bow mounts, **(item 8)** installed earlier in step 4, using one 1/4 hex bolt, **(item 11)** and one 1/4" locknut, **(item #13)**. Install in the rear holes of the bow brackets and in the single offset hole in the bow release brackets. **Note: this item must be able to pivot so do not overtighten the locknuts. Also the bolts must go through from the inside with the nuts on the outside.** Tighten using the two 7/16" wrenches or the 7/16" wrench and the 7/16" socket. Next slide one fabric bow sleeve, **(item #18)** onto each of the rear bow halves, **(item #19 L & R)**. **Note: the rear bow is the bow with the straight ends. The bow sleeves keep the metal tube from damaging the plastic windows.** Assemble the two halves by sliding the one with the sleeve into the one without. Place the rear bow, **(item #19)** into the bow release brackets, **(item #12)** installed earlier. Place the bottom of the bow with the hole into the center of the 3 holes in the bow release bracket. Secure to the release bracket with one bolt, **(item #6)** and one locknut, **(item #13)**. **Note: as before these must pivot so do not overtighten. Furthermore due to the slight differences in the bows it may be necessary to bend the bottom of the bows in out slightly to keep the center of the bow together or to get it to fit into the bracket. Also the holes in the bow release bracket are for tension adjustment on the top when the bow is in the locked position figure 7-F. If your top is too loose move the bow forward to the top of the 3 holes in the release bracket, if it is too tight move it to the rear bottom hole of the release bracket.** Next slide the last two fabric bow sleeves, **(item 18)** onto the two halves of the front bow, **(item 20 L & R.)** **Note: the front bow has a hooked end and the large holes punched at the top, which is not used, must face forward. See figure 6.** Secure the front bow to the front set of holes in the bow mount, **(item #8)** using the hex bolts **(item #11)** and the locknuts, **(item #13)** see **figure 6.** **Note: as before these must pivot so do not overtighten. Furthermore due to the slight differences in the bows it may be necessary to bend the bottom of the bows in or out slightly to keep the center of the bow together or to get it to fit into the bracket. You are now done with the hardware installation.**

Fabric Installation

Step 1: Unpack top and layout on clean surface and unzip and remove the rear curtain and the side curtains. Set the curtains aside and take the top and place it in the vehicle. Note the two bags are for storing your side curtains and rear curtain when not in use.

Step 2: Climb inside vehicle and take top by the front edge, the edge with the plastic sewn into it, **see figure 7-A on page 7**. Facing the front of the vehicle with the top vinyl side up and letting the rest of the top drop down in front of you, begin to tuck the plastic into the channel on the cab aluminum as shown in **figure 7-B**. Make sure to center the center of the plastic on the top with the center of the channel on the cab aluminum. **NOTE: MAKE SURE TO TUCK THE VERY FRONT EDGE WITH THE FABRIC AND PLASTIC INTO THE CHANNEL, DO NOT CLIP THE BACK EDGE OF THE PLASTIC ONTO THE CHANNEL AS IT WILL LIKELY DAMAGE YOUR TOP AND WILL RESULT IN A POOR FITTING TOP AND COULD RESULT IN IT BLOWING OFF WHEN THE VEHICLE IS IN MOTION. Refer to figure 7-A.**

Work from the center of the cab aluminum out to each side tucking the top and plastic into the channel on the cab aluminum. Continue to tuck the top and plastic in until you are just below the corner radius on the cab aluminum on both sides. **Do not tuck completely to the bottom of the cab aluminum channel at this time.**

Step 3: Now lift up front bow and while holding front bow, you may need help to hold the bow, lift the top up and over the front bow. Now snap the two front bow flaps onto the bow (2 flaps with 2 snaps each). **See figure 7-C**. Then lift up rear bow and while holding up rear bow lift top up and over rear bow and snap rear bow flap onto rear bow. (1 flap with 6 snaps). Climb out of vehicle.

Step 4: Now hook the rear corner K-locks into the channel on rear body aluminum. **See figure 8-A**. They will be loose and may not stay in very well at this time. Now get both side curtains and zip them onto the top. Make sure to tuck the small tabs of plastic, located at the front bottom edge of the curtains, into the front body aluminum. You can also try and hook 1 or 2 of the K-locks on the side curtain into the channel on the front body aluminum they will be loose and may not stay in very well at this time.

Step 5: Now go around to the rear of the vehicle and reach in and grab the rear bow on the side in the middle above the bow mount and lock, make sure to not grab it too close to the bow lock as this may pinch your hand when it pivots up. Now pull back on the rear bow to place the rear bow in the locked position. **See figure 7-F. Note: Make sure to slide the fabric bow sleeve up and out of the way of the bow lock.** Repeat the same procedure on the other side. Pivoting the bow lock up into the locked position provides the tension to keep the top in place and it must be in the locked position when driving to keep the top from coming loose and blowing off. If the top stretches over time or seems too loose then you can move the rear bow up to the top hole in the bow lock and this will provide more tension and if it seems to tight then move it down to the bottom hole in the bow lock.

Step 6: Now take the rear curtain and zip it onto the top. Now tuck the remainder of the front plastic into the channel on the cab aluminum. Tuck the plastic at the bottom of the rear curtain into the the channel on the tailgate aluminum. **(See figure 7E & 8B)** Then complete hooking the K-locks onto the channel of the body aluminum on the side curtains and the corners. **(See figure 8.)** You may want to install one 6" piece of stick on weatherstrip, (Item 16) in the bottom corner of the body between the body aluminum and the cab aluminum to make a more water-tight seal (see figure 2 on page 3) Cut the weatherstrip in half and clean the area on the body with rubbing alcohol before installing the weatherstrip. **You are now done with installing your top.**

Folding Instructions

Before unzipping the curtains make sure to unlock the rear bow. The curtains can be stored flat or they can be stored in the bags provided. Before storing the curtains, clean the windows with mild non-detergent soap and water. If the windows are not clean, dirt will scratch the windows reducing the life of the curtains. **It is also advisable to place a soft cloth on the windows prior to storing them to prevent them from scratching and marring each other.** To remove the side curtains unzip the rear curtain and reach in and unlock the rear bow. Unzip the side curtains and the rear curtain, if removing, and then unhook the K-locks and the plastic from the body aluminum and the tailgate. Then relock the rear bow, making sure that the rear corner K-locks are in place as well as the plastic on the cab aluminum and the plastic is seated on the rear curtain if you did not remove the rear curtain. Now with the windows clean and with a soft cloth against the windows roll fold the curtains at the spaces between the K-locks and store in the bag. Roll fold the rear curtain and store it in the bag provided. **Note: Do not crease the window glass or fold too severely or lay heavy objects on the folded windows or it will damage the glass.**

To fold down your soft top follow these directions: **See figure 9 on page 8. You will need at least 2 people to do this properly. It is best to remove the tailgate aluminum before folding the top down as the weight of the top and bows may cause damage to the tailgate aluminum.**

Step 1. Unzip the rear curtain and reach in and unlock the rear bow both sides. Unzip and remove the side curtains and the rear curtain.

Step 2. Unhook the K-locks on the rear corners and flip the rear corners up onto the top of the convertible top.

Step 3. Remove the plastic on the top from the cab aluminum channel, make sure someone is holding up the bows from the inside of the vehicle or they will all crash back onto the tailgate and may damage the top and the tailgate.

Step 4. Now push the two bows together making sure that the top sags down between them. Now while one person is holding up the top and bows fold the front of the convertible top towards the rear of the vehicle over the bows and wrap it around the top and bows.

Step 5. Now carefully lay the the bows and the top back until it comes to rest on the tailgate being carefull not to pinch the vinyl as it may cause a wear point. There is a convertible boot available to cover and protect your top while it is in the down position. Contact your dealer for pricing and availability.

CARE INSTRUCTIONS

Convertible tops and accessories require special care if you want to get the maximum usage and enjoyment from them. The following recommendations, if followed carefully, can extend the life of your top or accessory.

1. Hand wash using a mild non-detergent soap such as Ivory. Use a nonabrasive cloth or sponge. Rinse thoroughly.
2. **DO NOT** wash in direct sunlight and avoid automatic car washes.
3. When your top is clean, we recommend using "RAGGTOPP" Vinyl Protectant on both the vinyl top and windows. This product helps protect from the sun's damaging rays. Stay away from products containing alcohol as it will cause the fabric and windows to lose their elasticity, thus reducing the life of your top or accessory. If you are unable to locate "RAGGTOPP", please call 1-800-377-4700 or on the web www.wolfsteins.com for a distributor near you.
4. Direct sunlight and heat are the biggest enemies of the windows. Park in the shade whenever possible. If you must park in the sunlight, rotate the direction that you park every few days so all windows get even exposure.
5. Our tops are designed so that you may roll up and/or store the rear curtain and side curtains. To prevent scratching of the windows, be sure that windows are completely clean and free of dust particles. Even a little dirt will badly scratch the windows. You may want to use a soft cloth when rolling up or storing your windows. Heat may build up on rolled up windows, so be sure to unroll them frequently. If you roll up the windows at the beginning of summer and leave them, they may be ruined by fall.
6. **DO NOT** open or roll up windows at temperatures below 45 degrees F. This could cause them to crack or break.
7. **NEVER** use ice scrapers or snow brushes on vinyl windows.

WARRANTY INFORMATION:

Specialty Top Co. warrants to the original purchaser of any product it manufactures, that the product will be free of defects in material or workmanship for a period of 90 days from date of purchase. Such obligations under this warranty shall be limited to the repair or replacement, at Specialty's discretion, of any assembly or parts which upon examination by Specialty Top Co. proves to be defective. All defective items must be returned with proof of purchase to Specialty Top Co., 200 East 64th Avenue, Denver, Colorado 80221, freight prepaid. This warranty does not cover damage resulting from abuse, misuse, alteration, accident or damage in transit. Specialty's obligations under this warranty are limited to the aforementioned repair or replacement of warranty defects for which the return authorization has been received during the warranty period, and **SPECIALTY TOP CO. SHALL NOT BE LIABLE FOR ANY INCIDENTAL OR CONSEQUENTIAL DAMAGES ARISING FROM BREACH OF THIS OR ANY IMPLIED WARRANTY.**

Some states do not allow the exclusion or limitation of incidental or consequential damages, so the above limitation or exclusion may not apply to you. This warranty gives you specific legal rights, and you may also have other rights which may vary from state to state.

If you need assistance or further information, you may contact Specialty Top Co. at 1-866-487-9944 between the hours of 8:00 AM and 4:00 PM, Monday through Friday, Mountain Standard Time.