



SPECIALTY TOP CO.

INSTALLATION INSTRUCTIONS 4-RUNNER PART #228-010

Thank you for purchasing Specialty's Convertible Top for your 4-Runner vehicle. It has been designed for great fit and long wear. Please read and follow, precisely, all installation instructions provided when installing top. Failure to do so may result in a poor fitting top and could place occupants in a potentially hazardous situation.

TOOLS REQUIRED:

- | | |
|-------------------------|-----------------|
| 3/8" WRENCH | 7/16" WRENCH |
| 1/8" DRILL BIT | 5/32" DRILL BIT |
| 3/16" DRILL BIT | 1/2" DRILL BIT |
| ELECTRIC DRILL | 8' TAPE MEASURE |
| #2 PHILLIPS SCREWDRIVER | |

front to rear. Using body aluminum as a template, mark and drill 1/8" holes. Secure to body with #10 x 1/2" sheet metal screws (Item 2). But front body aluminum (Item 3) next to rear body aluminum and install using same procedure as above. See figure 1.

INSTALLATION TIPS

Before you begin installing this top, here are a few tips to make installation easier.

This top should be installed where the temperature is above 72 degrees Fahrenheit. Below this temperature, the top may contract making it difficult to install.

It is normal for a top to contract and wrinkle when stored in the shipping carton. The top will relax and wrinkles will disappear within a few days of installation as fabric adjusts to shape of mounting hardware.

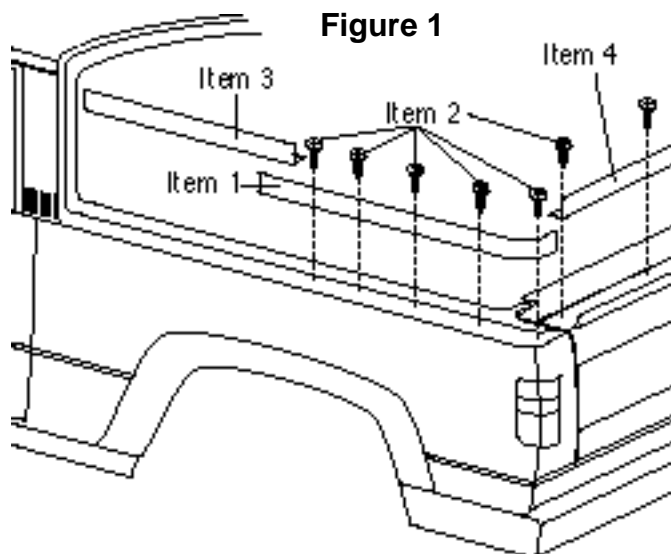

INSTALLATION PROCEDURES:

On page 4 of this instruction manual there is an assembly drawing. Please refer to it for identification of parts and assembly assistance. Also refer to page 5 to assure that all parts are included in your kit.

Step 1. Body Aluminum. Mount rear body aluminum (Item 1) to top edge of body. Locate body aluminum against rise in body so that the angle at rear of body aluminum matches angles at rear corners of vehicle at the tailgate. Body aluminum should be parallel to vehicle body

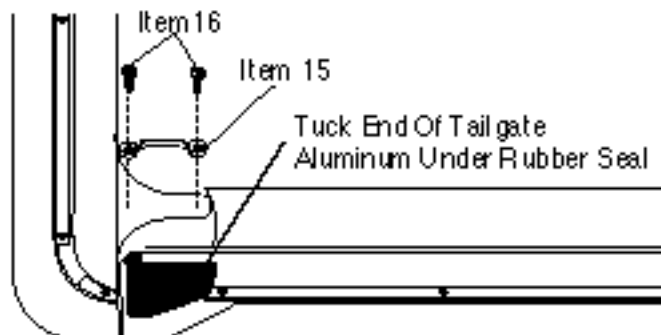

Step 2. Tailgate Aluminum. Mount tailgate aluminum (Item 4) to the top edge of tailgate centered from side to side. Tailgate aluminum should be mounted as far to the rear of flat edge on tailgate as possible. Ends of tailgate aluminum must be placed underneath rubber seal at ends of tailgate. Using tailgate aluminum as a template, mark and drill 1/8" holes. Secure to body with #10 x 1/2" sheet metal screws (Item 2). See figure 1.

Step 3. Cab Aluminum. Remove rubber weather strip from rear of cab. Save for future use with your hard top. Measure up 3/16" from top of body at rear of cab on the drivers side. This will be the starting point for mounting the cab aluminum. Place rounded end of left cab aluminum (Item 5- long piece) at this point. Mark and drill 1/8" holes using cab aluminum as a template starting at the bottom and working your way to top center of cab. Install one #10 x 1/2" sheet metal screw (Item 2) at a time keeping front of cab aluminum as far forward as possible and bending to follow contour of vehicle. See figure 2. Butt end of right cab aluminum (short piece) to cab aluminum just installed and secure to cab using same procedure as above. See figure 2-A.

Step 4. Bow Mount. Measure 42" from vertical edge at rear of cab and mark for position of bow mount (Item 6). Place front of bow mount at this point. The rear inside hole in bow mount should be above directly over an original hard top mounting hole (fourth hole from cab). Using bow mount as a template, mark and drill two 5/32" holes, one at the front outside of bracket and one at the rear outside of bracket. Secure with #14 x 1/2" hex head sheet metal screws (Item 7). Repeat for the other side. See figure 3.

Step 5. Bows. Secure bow release bracket (Item 8) to bow mount by placing 1/4-20 x 1 1/2" hex head bolt (Item 9) through one side of bow mount, the bow release bracket and the other side of bow mount. Secure with 1/4-20 lock nut (Item 10). These items must pivot so do not over tighten. Repeat for other side. Place bow sleeves (Item 11) over rear bows (Item 12). Slide rear bow halves together. Mount rear bow into center set of holes in bow release bracket by placing 1/4-20 x 1 1/2" hex head bolt (Item 9) through one side of release bracket, rear bow and then through the other side of release bracket. Secure with 1/4-20 lock nut (Item 10). Again these items must pivot so do not over tighten. Repeat for other side. Slide bow sleeves (Item 11) over front bow halves (Item 13). Place front bow into front of bow mount so that the large holes in bow are facing towards the front of vehicle. Secure front bow to bow mount with 1/4-20 x 1 1/2" hex head bolt through one side of bow mount, front bow and other side of bow. Secure with 1/4-20 lock nut. Once more these items must pivot so do not over tighten. Repeat for other side. See figure 3.

Figure 2

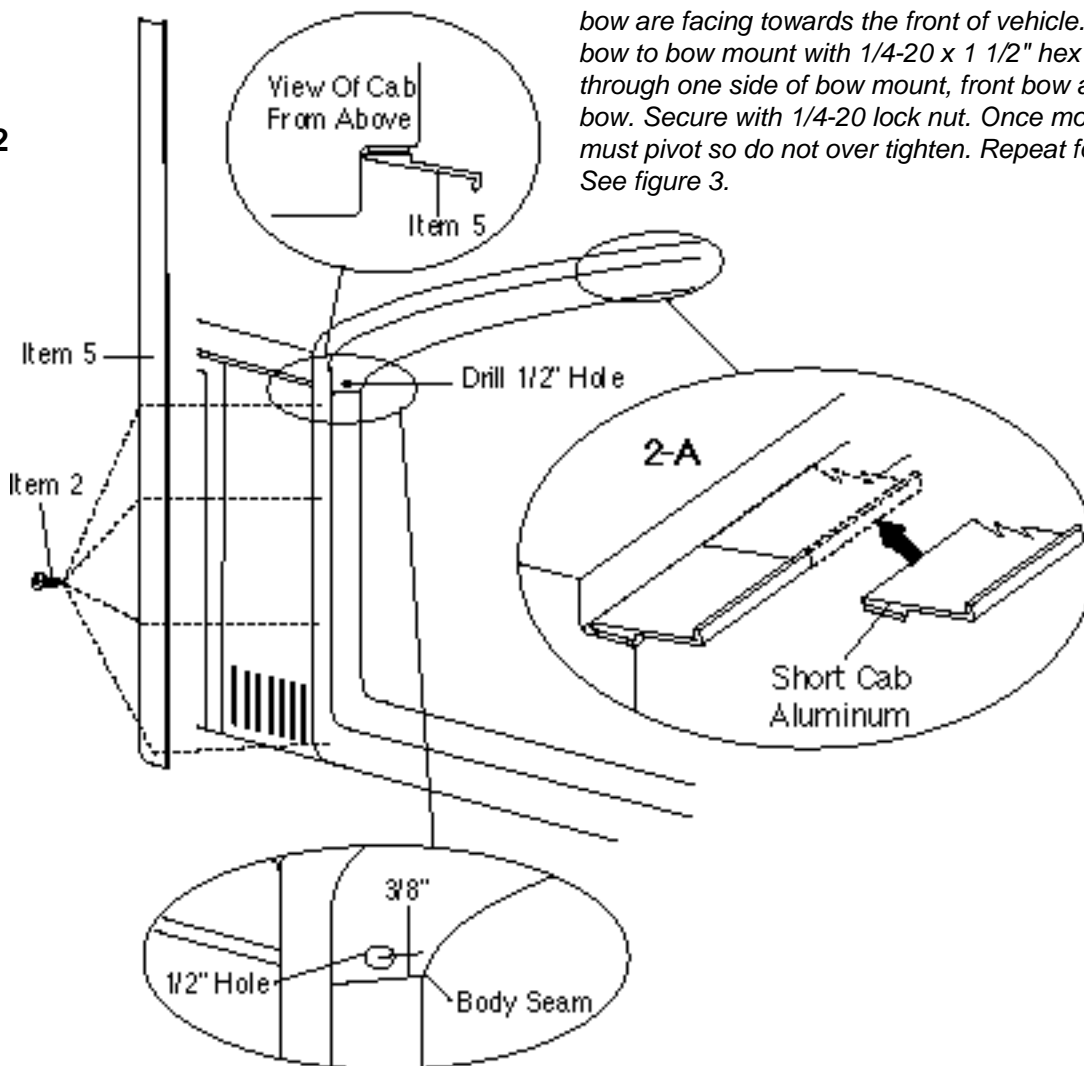

Step 6. Horizontal Rods. Mark and drill 1/2" hole, 3/8" above body seam at rear of cab centered from side to side. Pull front bow forward and insert small end of horizontal rod into hole in front bow. Insert other end into 1/2" hole drilled in rear of cab. See figure 4-A and 4-C.

Step 7. Footman Loop. Place footman loop (Item 15) on top of body at rear corner of vehicle. See figure 1. Mark and drill 1/8" holes using footman loop as a template. Secure to body with #8 x 1/2" oval head sheet metal screws (Item 16). See figure 1.

Installing Vinyl Top. Find and mark center line on top of cab aluminum. Mark and drill 1/8" hole on this line 5/8" from front of cab aluminum. Install 3/8" sheet metal screw stud (Item 17). Snap front center snap to stud just installed. Front of vinyl top should be against rear of cab. Continue installing sheet metal screw studs in cab aluminum, alternating from left to right of center line. To avoid wrinkles, gently pull top to the side, mark and drill cab aluminum using position of snaps on vinyl top as a guide. Continue this process across the top and down each side of cab snapping each snap to each stud as you go. Snap rear bow flap on vinyl top to rear bow. See figure 4-D. Measure and mark a center line on tailgate aluminum. Drill a 3/16" hole at this point, centered from top to bottom on tailgate aluminum. Place #10-32 machine screw stud (Item 18) through the hole and secure with #10-32 hex nut (Item 19). Snap rear curtain to stud just installed. Lock rear bow into position (as shown in figure 4-E). Continue installing machine screw studs, alternating from left to right of center using snaps on rear curtain as a guide. Pull down and to the side on rear curtain when locating studs. Snap top to each stud before installing next stud. Studs for snaps at sides of rear curtain should be installed on body aluminum. Install machine screw studs, for side panel, in body aluminum starting at the rear. Pull side panel to the rear and down to find location of stud. It should be located at the bend in the body aluminum. Repeat for the other side. Install remaining studs on body aluminum using snaps on side panel as a guide. The bottom of the side panel should touch the top edge of vehicle.

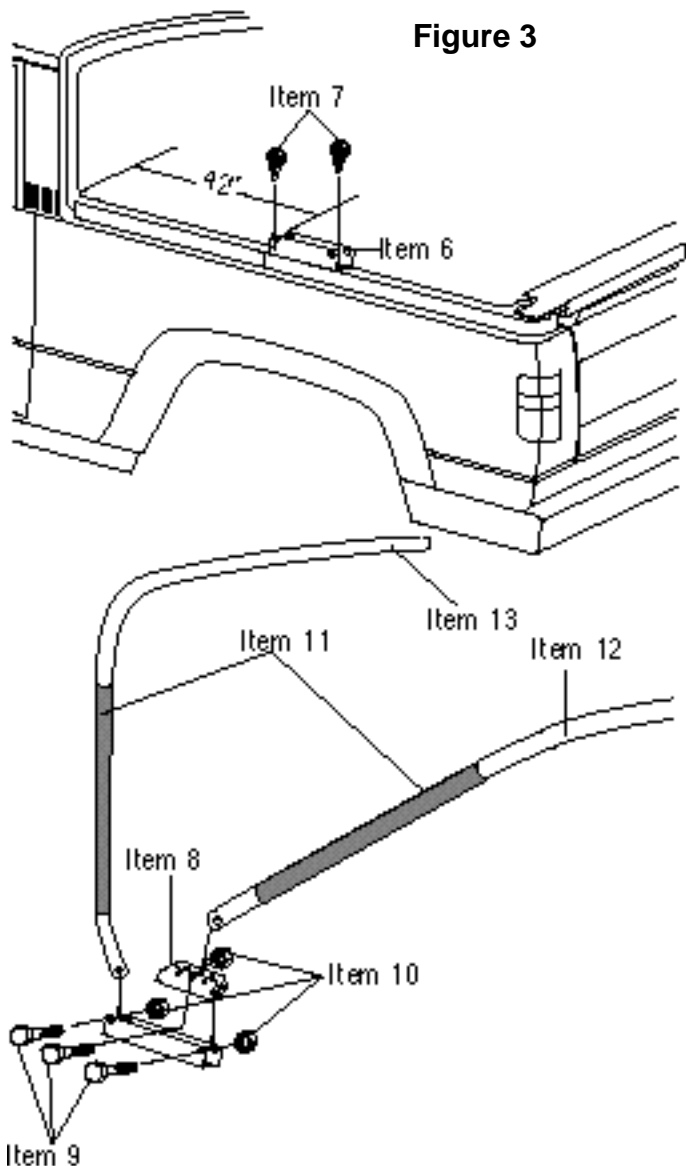

Figure 3

WARRANTY INFORMATION:

Specialty Top Co. manufacturing warrants to the original purchaser of any product it manufactures, that the product will be free of defects in material or workmanship for a period of 90 days from date of purchase. Such obligations under this warranty shall be limited to the **repair or replacement**, at Specialty's discretion, of any assembly or parts which upon examination by Specialty Top Co. proves to be defective. All defective items must be returned with proof of purchase to Specialty Top Co. Manufacturing, 200 East 64th Avenue, Denver, Colorado 80221, freight prepaid. This warranty does not cover damage resulting from abuse, misuse, alteration, accident or damage in transit. Specialty's obligations under this warranty are limited to the aforementioned repair or replacement of warranty defects for which the return authorization has been received during the warranty period, and **SPECIALTY TOP CO. SHALL NOT BE LIABLE FOR ANY INCIDENTAL OR CONSEQUENTIAL DAMAGES ARISING FROM BREACH OF THIS OR ANY IMPLIED WARRANTY.**

Some states do not allow the exclusion or limitation of incidental or consequential damages, so the above limitation or exclusion may not apply to you. This warranty gives you specific legal rights, and you may also have other rights which may vary from state to state.

If you need assistance or further information, you may contact Specialty Top Co. at 1-866-487-9944 between the hours of 8:00 AM and 5:00 PM, Monday through Friday, Mountain Standard Time.

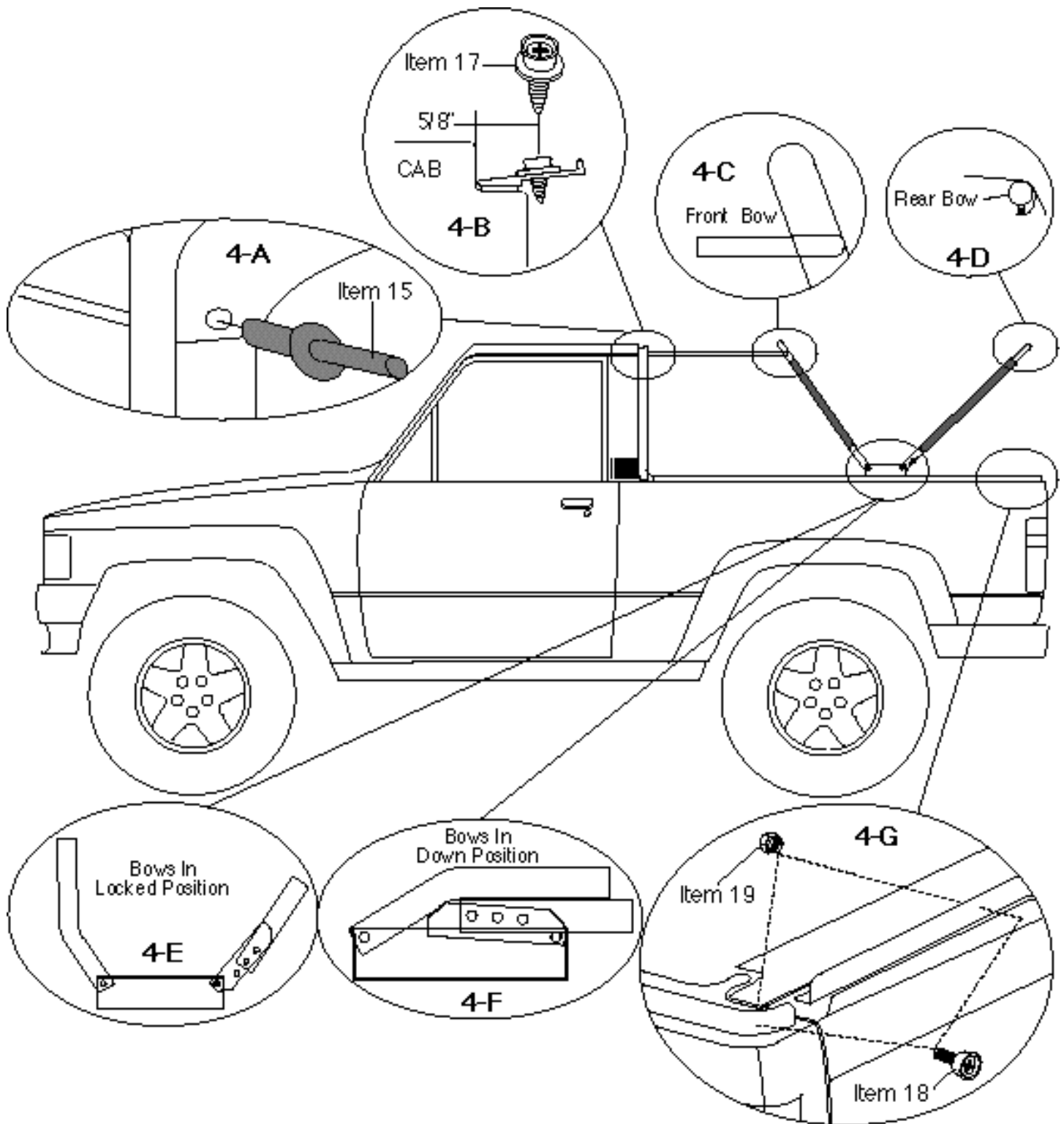

PARTS IDENTIFICATION

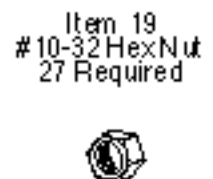
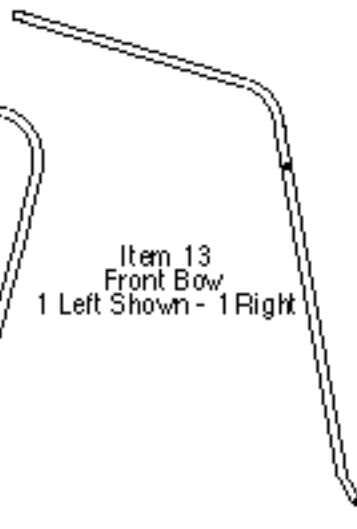
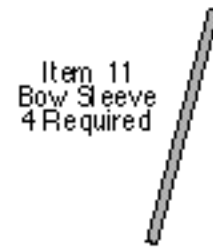
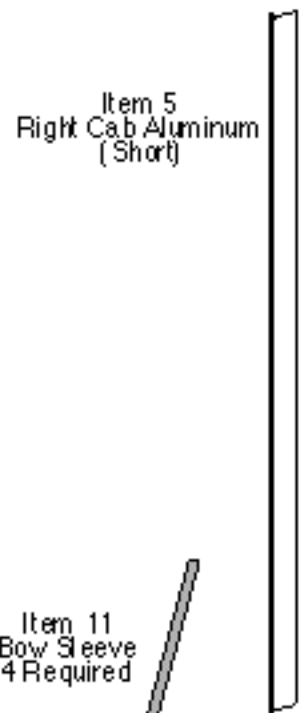
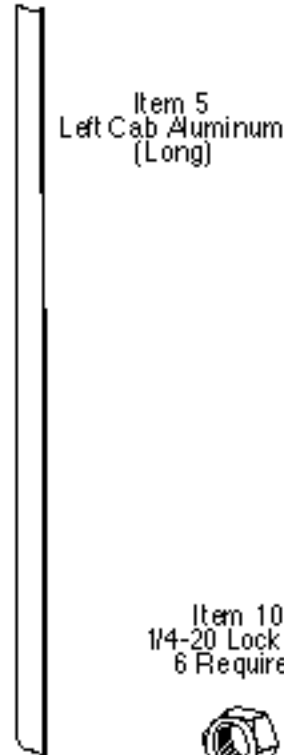
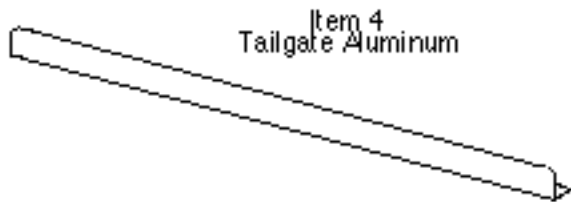
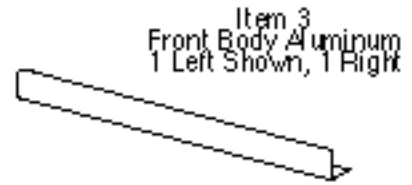
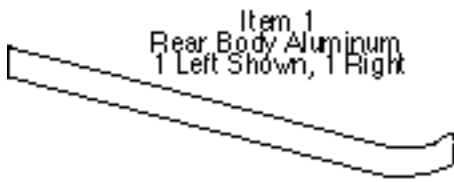

Rolling Up Side Panels. It is possible to roll up your side curtains to provide more ventilation in your vehicle. Prior to rolling side or rear curtains you must first make sure that windows are clean. If not properly cleaned dirt will scratch them reducing top life. To clean windows, wash them with a mild non-detergent soap and water. To roll up side curtain, unzip rear curtain zippers, unlock rear bow, unsnap curtain and roll up curtain. Secure with retaining straps on top. Lock rear bow, buckle and tighten rear bow hold down straps. To roll up rear curtain follow the same procedure. You may roll up both side and rear curtains if you wish.

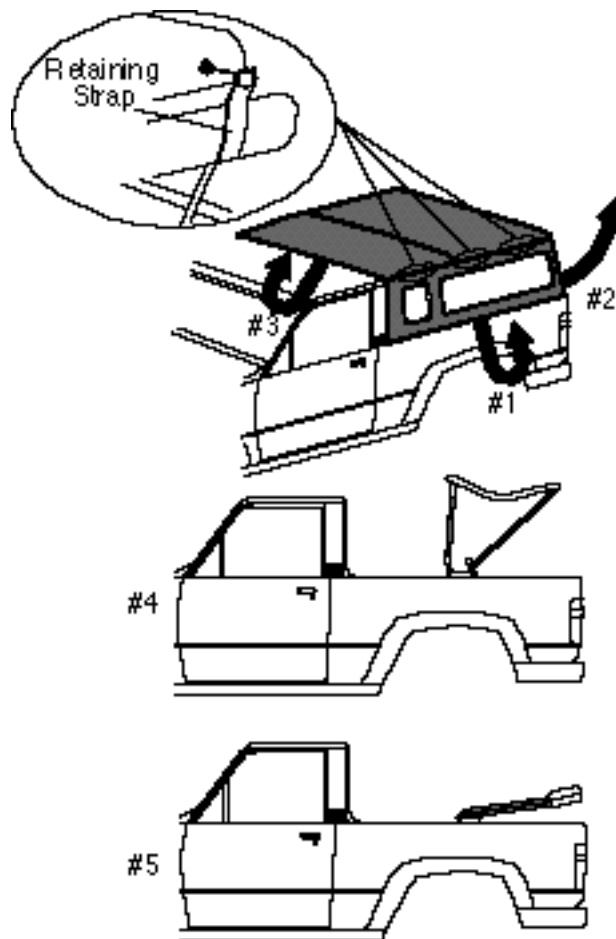

FOLDING INSTRUCTIONS

Step 1. Unlock rear bow and unfasten snaps. Lift side curtains up and fold them on top of bows.

Step 2. Lift rear curtain up and fold it on top of bows.

Step 3. Remove horizontal rods. Fold front of top to the rear, over bows.

Step 4. As you pull the front of top and bows to the rear of vehicle, let the top sag **in between bows**.

Step 6. Continue to lay bows down and let them come to rest on top of tailgate.

CARE INSTRUCTIONS

Convertible tops and accessories require special care if you want to get the maximum usage and enjoyment from them. The following recommendations, if followed carefully, can extend the life of your top or accessory.

1. Hand wash using a mild non-detergent soap such as Ivory. Use a nonabrasive cloth or sponge. Rinse thoroughly.
2. **DO NOT** wash in direct sunlight and avoid automatic car washes.
3. When your top is clean, we recommend using "303 Protectant" on both the vinyl top and windows. This product contains a sunscreen that helps protect from the sun's damaging rays. Stay away from products containing alcohol as it will cause the fabric and windows to lose their elasticity, thus reducing the life of your top or accessory. If you are unable to locate "303 Protectant", please call 1-800-223-4303 for a distributor near you.
4. Direct sunlight and heat are the biggest enemies of the windows. Park in the shade whenever possible. If you must park in the sunlight, rotate the direction that you park every few days so all windows get even exposure.
5. Our tops are designed so that you may roll up and/or store the rear curtain and side curtains. To prevent scratching of the windows, be sure that windows are completely clean and free of dust particles. Even a little dirt will badly scratch the windows. You may want to use a soft cloth when rolling up or storing your windows. Heat may build up on rolled up windows, so be sure to unroll them frequently. If you roll up the windows at the beginning of summer and leave them, they may be ruined by fall.
6. **DO NOT** open or roll up windows at temperatures below 45 degrees F. This could cause them to crack or break.
7. **NEVER** use ice scrapers or snow brushes on vinyl windows.