



SPECIALTY TOP CO.

INSTALLATION INSTRUCTIONS TOYOTA LANDCRUISER HALFDOORS PART #222-003

Thank you for purchasing Specialty's Doors for your vehicle. They have been designed for great fit and long wear. Please read and follow, precisely, all installation instructions provided when installing your doors. Failure to do so may result in a poor fitting doors and could place occupants in a potentially hazardous situation.

TOOLS REQUIRED:

7/16" WRENCHES 1/2" WRENCH
SCISSORS 7/32" ALLEN WRENCH

Step 1. Hinges. As these half doors utilize original hard door hinges will need to be removed from your original doors. Cut holes in fabric using holes in door hinge as a guide. Position lower half of door frame into door opening on vehicle. Place 1/4-20 x 3/4" hex bolt (Item 1) through 1/4" flat washer (Item 2), existing body hinge, door fabric and into hole in hinge on door. Secure with another 1/4" flat washer and 1/4-20 hex nut (Item 3). Do not fully tighten at this time. Repeat for the other side.

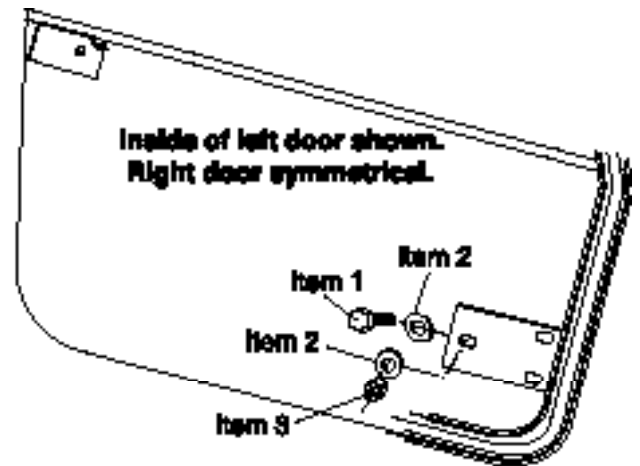

Step 2. Handle. Place handle cover (Item 4) over inside handle (Item 5). Place square peg through hole in latch plate on door. Place 3/8" flat washer (Item 6) over peg. Slip outside handle (Item 7) over peg on inside handle. Press handle assembly together and tighten allen screw on outside handle. Adjust for fit in door opening and tighten all fasteners. Repeat for the other side.

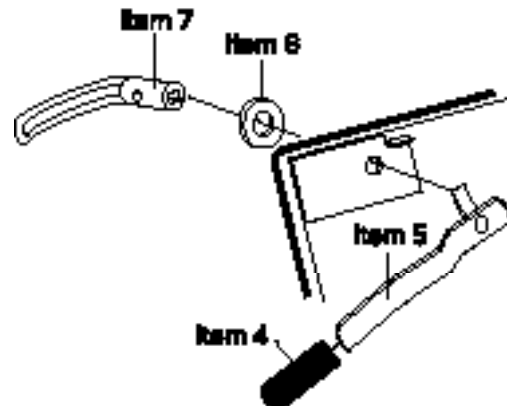

CARE INSTRUCTIONS

Convertible tops and accessories require special care if you want to get the maximum usage and enjoyment from them. The following recommendations, if followed carefully, can extend the life of your top or accessory.

- 1. Hand wash using a mild non-detergent soap such as Ivory. Use a nonabrasive cloth or sponge. Rinse thoroughly.*
- 2. **DO NOT** wash in direct sunlight and avoid automatic car washes.*
- 3. When your doors are clean, we recommend using "303 Protectant" on both the vinyl and windows. This product contains a sunscreen that helps protect from the sun's damaging rays. Stay away from products containing alcohol as it will cause the fabric and windows to lose their elasticity, thus reducing the life of your top or accessory. If you are unable to locate "303 Protectant", please call 1-800-223-4303 for a distributor near you.*

WARRANTY INFORMATION:

*Specialty Top Co. warrants to the original purchaser of any product it manufactures, that the product will be free of defects in material or workmanship for a period of 90 days from date of purchase. Such obligations under this warranty shall be limited to the **repair or replacement**, at Specialty's discretion, of any assembly or parts which upon examination by Specialty Top Co. proves to be defective. All defective items must be returned with proof of purchase to Specialty Top Co., 200 East 64th Avenue, Denver, Colorado 80221, freight prepaid. This warranty does not cover damage resulting from abuse, misuse, alteration, accident or damage in transit. Specialty's obligations under this warranty are limited to the aforementioned repair or replacement of warranty defects for which the return authorization has been received during the warranty period, and **SPECIALTY TOP CO. SHALL NOT BE LIABLE FOR ANY INCIDENTAL OR CONSEQUENTIAL DAMAGES ARISING FROM BREACH OF THIS OR ANY IMPLIED WARRANTY.***

Some states do not allow the exclusion or limitation of incidental or consequential damages, so the above limitation or exclusion may not apply to you. This warranty gives you specific legal rights, and you may also have other rights which may vary from state to state.

If you need assistance or further information, you may contact Specialty Top Co. at 1-866-487-9944 between the hours of 8:00 AM and 5:00 PM, Monday through Friday, Mountain Standard Time.