



SPECIALTY TOP CO.

INSTALLATION INSTRUCTIONS CJ-5 HALF DOOR PART #105-003

Thank you for purchasing Specialty's Half Doors for your vehicle. They have been designed for great fit and long wear. Please read and follow, precisely, all installation instructions provided when installing top. Failure to do so may result in poor fitting doors and could place occupants in a potentially hazardous situation.

INSTALLATION PROCEDURES:

Step 1. Slide 5/16 X 3/4 carriage bolt (Item 1) between fabric and slots in pivot plate. Place door pivots (Item 2) over bolts. Place 5/16 flat washer (Item 3) over bolts and secure with 5/16-18 lock nuts (Item 4). Do not fully tighten at this point.

Step 2. Slide handle cover (Item 5) onto inside handle (Item 6). Place handle over bolt on door. Place 5/16 washer over bolt and secure with 5/16-18 lock nut. Tighten so handle moves freely.

Step 3. **For 1955-1975 CJ-5 Only.** Place body hinge (Item 7) directly in line with the bottom of windshield hinge. Mark and drill 9/32" holes at this point using body hinge as a template. Place 1/4-20 x 3/4" hex bolt (Item 8) through 1/4 flat washer (Item 9), body hinge and through drilled hole. Secure with another 1/4 flat washer and 1/4-20 lock nut. Measure 11 1/2" from top of upper body hinge to top of lower body hinge and secure to body as stated above.
Step 4. Place door pivots into body hinges. Adjust door to best fit door opening and handle function. Tighten 5/16-18 lock nuts.

TOOLS REQUIRED:

1/2" WRENCH
1955-1975 CJ-5 ONLY
2-7/16" WRENCHES 9/32" DRILL BIT
ELECTRIC DRILL

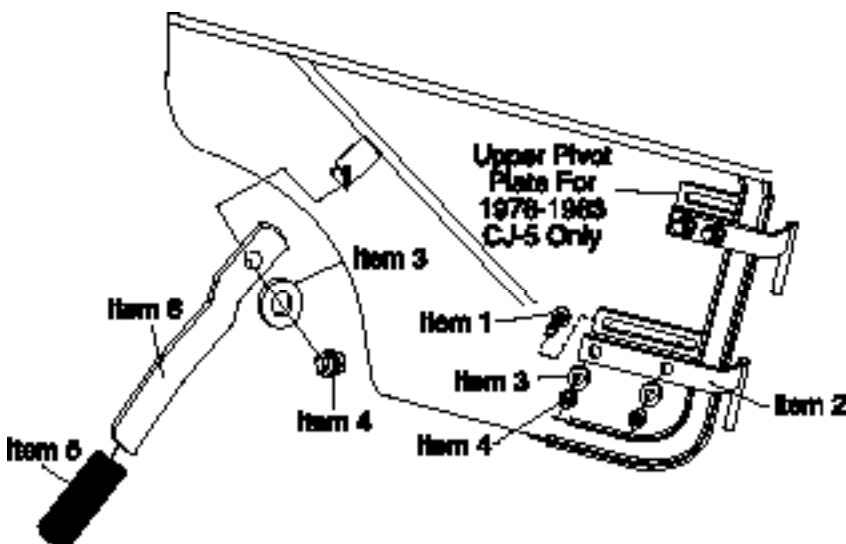
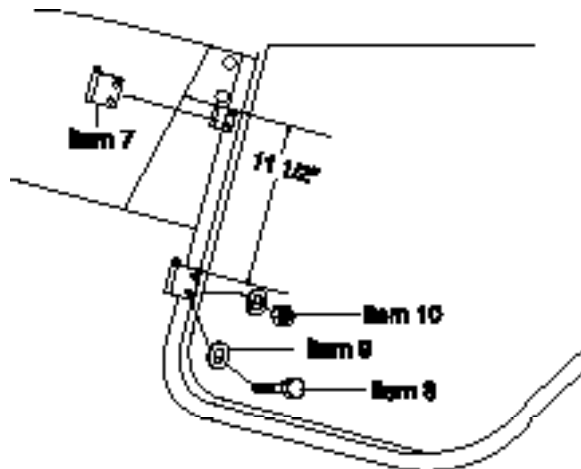

CARE INSTRUCTIONS

Convertible tops and accessories require special care if you want to get the maximum usage and enjoyment from them. The following recommendations, if followed carefully, can extend the life of your top or accessory.

1. Hand wash using a mild non-detergent soap such as Ivory. Use a nonabrasive cloth or sponge. Rinse thoroughly.
2. **DO NOT** wash in direct sunlight and avoid automatic car washes.
3. When your top is clean, we recommend using "303 Protectant" on both the vinyl top and windows. This product contains a sunscreen that helps protect from the sun's damaging rays. Stay away from products containing alcohol as it will cause the fabric and windows to lose their elasticity, thus reducing the life of your top or accessory. If you are unable to locate "303 Protectant", please call 1-800-223-4303 for a distributor near you.
4. Direct sunlight and heat are the biggest enemies of the windows. Park in the shade whenever possible. If you must park in the sunlight, rotate the direction that you park every few days so all windows get even exposure.
5. Our tops are designed so that you may roll up and/or store the rear curtain and side curtains. To prevent scratching of the windows, be sure that windows are completely clean and free of dust particles. Even a little dirt will badly scratch the windows. You may want to use a soft cloth when rolling up or storing your windows. Heat may build up on rolled up windows, so be sure to unroll them frequently. If you roll up the windows at the beginning of summer and leave them, they may be ruined by fall.
6. **DO NOT** open or roll up windows at temperatures below 45 degrees F. This could cause them to crack or break.
7. **NEVER** use ice scrapers or snow brushes on vinyl windows.

WARRANTY INFORMATION:

Specialty Top Co. warrants to the original purchaser of any product it manufactures, that the product will be free of defects in material or workmanship for a period of 90 days from date of purchase. Such obligations under this warranty shall be limited to the **repair or replacement**, at Specialty's discretion, of any assembly or parts which upon examination by Specialty Top Co. proves to be defective. All defective items must be returned with proof of purchase to Specialty Top Co., 200 East 64th Avenue, Denver, Colorado 80221, freight prepaid. This warranty does not cover damage resulting from abuse, misuse, alteration, accident or damage in transit. Specialty's obligations under this warranty are limited to the aforementioned repair or replacement of warranty defects for which the return authorization has been received during the warranty period, and **SPECIALTY TOP CO. SHALL NOT BE LIABLE FOR ANY INCIDENTAL OR CONSEQUENTIAL DAMAGES ARISING FROM BREACH OF THIS OR ANY IMPLIED WARRANTY.**

Some states do not allow the exclusion or limitation of incidental or consequential damages, so the above limitation or exclusion may not apply to you. This warranty gives you specific legal rights, and you may also have other rights which may vary from state to state.

If you need assistance or further information, you may contact Specialty Top Co. at 1-866-487-9944 between the hours of 8:00 AM and 5:00 PM, Monday through Friday, Mountain Standard Time.